

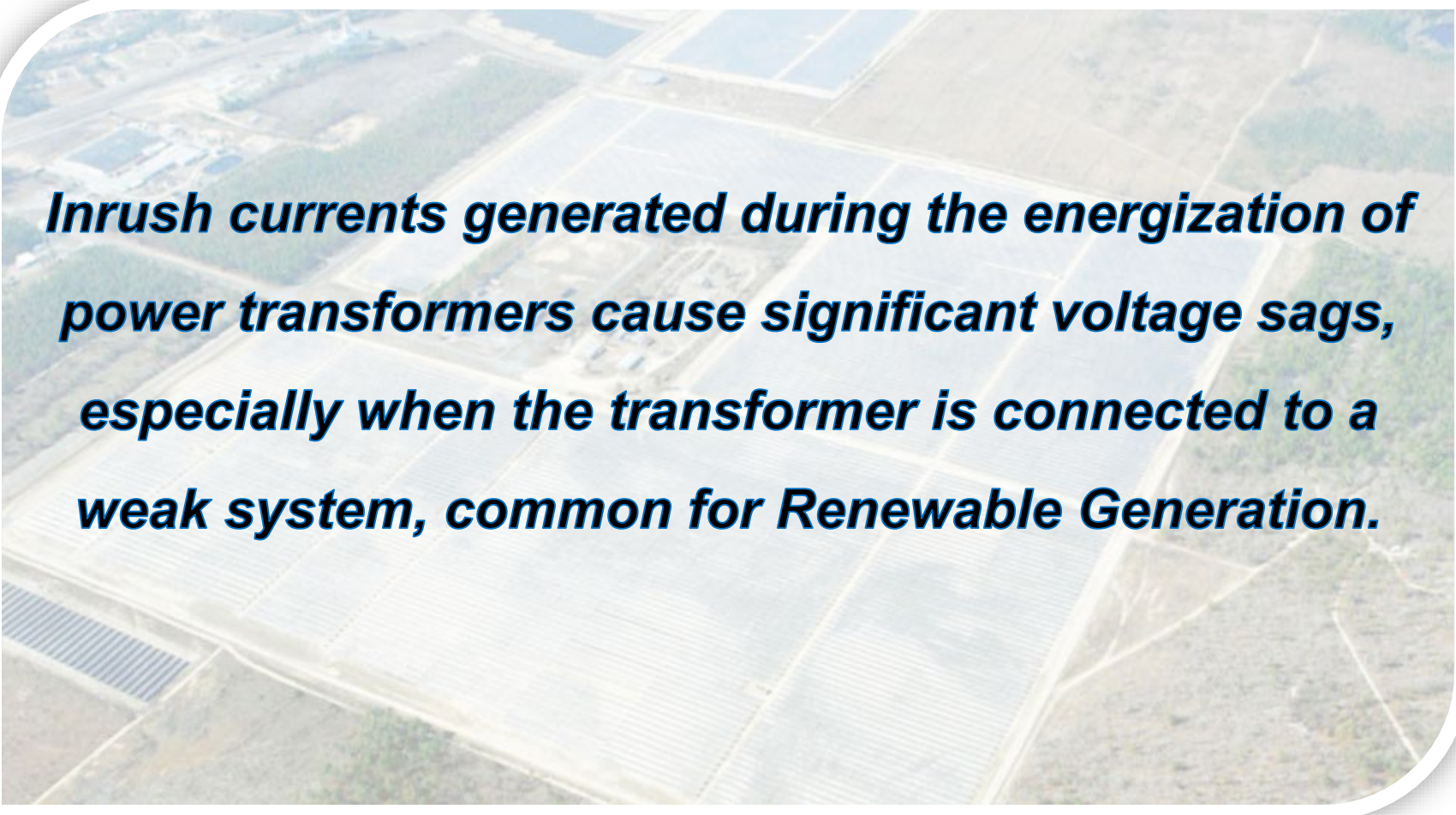

Mitigation of Inrush Current and Voltage Drop at Solar Farm Interconnections due to Transformer Energization using Closing Resistors



The Challenge



Inrush currents generated during the energization of power transformers cause significant voltage sags, especially when the transformer is connected to a weak system, common for Renewable Generation.

Constraints and Concerns

- Inrush Currents resulting from connecting a DER to a weak circuit, may cause a step voltage drop **greater than utility allowed limits** (typically 3 to 5%)
- DER transformers are switched more frequently than the traditional utility substation transformer
- The DER must be disconnected from the utility system to avoid islanding during supply interruptions
- To avoid no-load transformer losses, it is beneficial to disconnect the transformer from the utility system during periods where power is not being produced by the DER.

Considerations When Switching Transformers

Inrush Currents – Why are they an issue?

- The Inrush current impact on Voltage is much greater on weak circuits
- Unidirectional inrush currents cause transformer cores to go into deep saturation resulting in large voltage drops
- Inrush currents frequently exceed the transformers short circuit rating

Considerations When Switching Transformers

- **Inrush Current Magnitude is dependent on:**
 - **Switching point on the voltage wave**
 - **Magnitude and polarity of residual flux in the transformer**
 - **Source impedance**
 - **Size of the transformer**
 - **Magnetic properties of the core**
 - **Winding impedance and configuration**

This does get complicated FAST

A Solar Farm with an Interconnection Issue



A Problematic Interconnection Issue

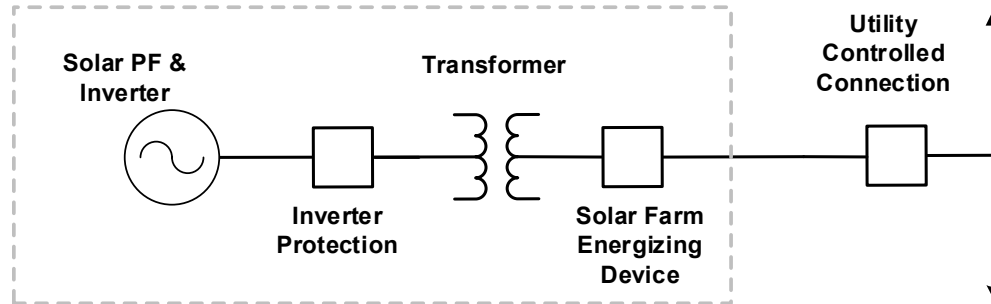
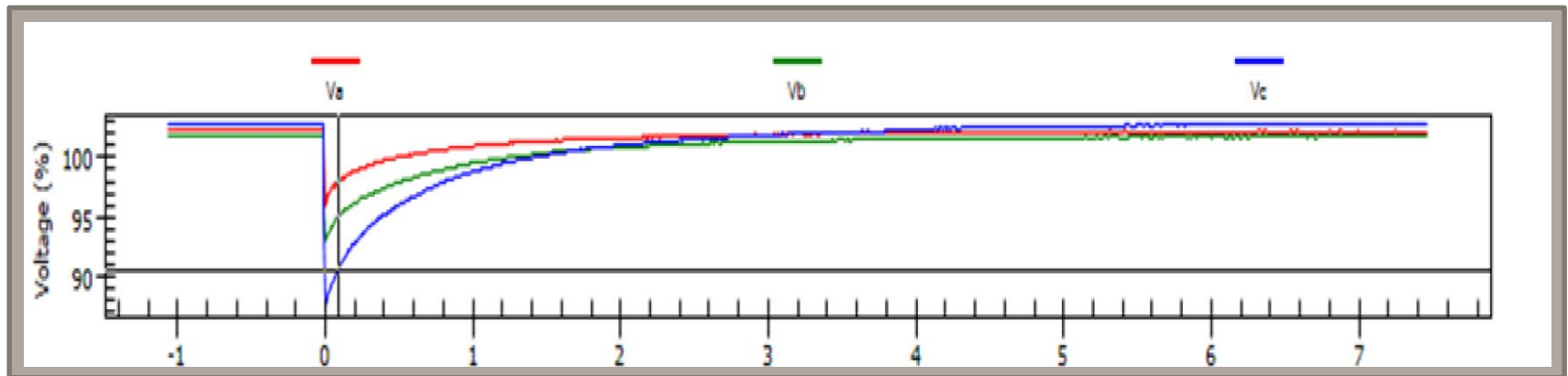
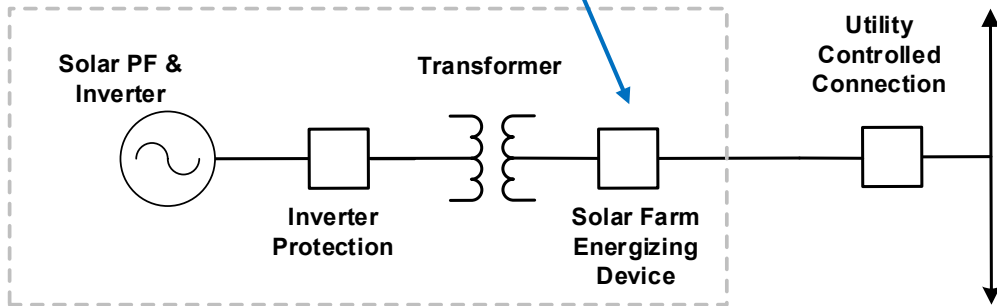
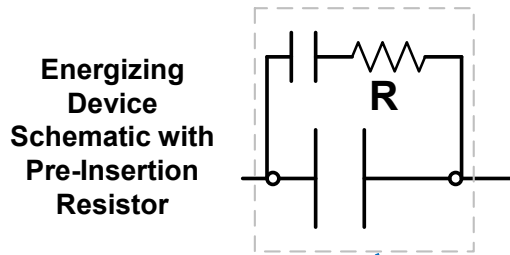

Illustration of Typical Solar Facility Interconnection to Utility System



Example of Rapid Voltage Drop due to Energization of a Solar Facility

Comparison of Traditional Energizing Device to One with Pre-Insertion Resistor



- **Traditional Device**
 - Recloser
 - Circuit Breaker

- **Alternative Device**
 - Vacuum Switcher with Pre-Insertion Resistor

Transformer Parameters Used For Simulations

Rated Power (MVA)	10
Rated Voltage (kV)	12.47/0.6
Impedance (%)	6
Knee Voltage (pu)	1.27
Air-core Reactance (pu)	0.105
Leakage Reactance (pu)	0.0525

Transformer Bus Voltage

Traditional Switching Device

No Residual flux

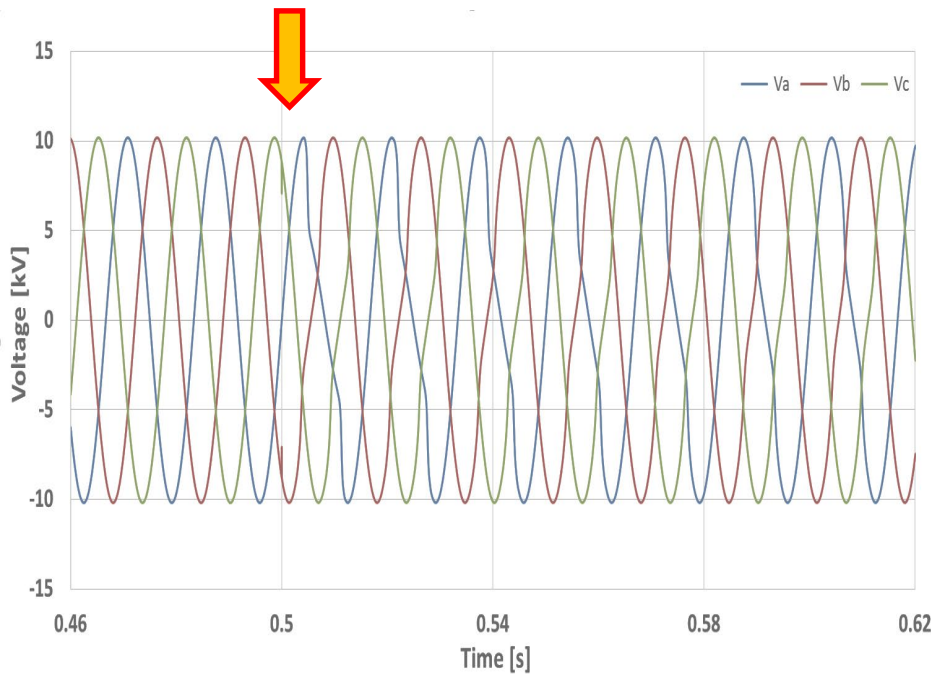

Residual flux (0.8, 0.0, -0.8)

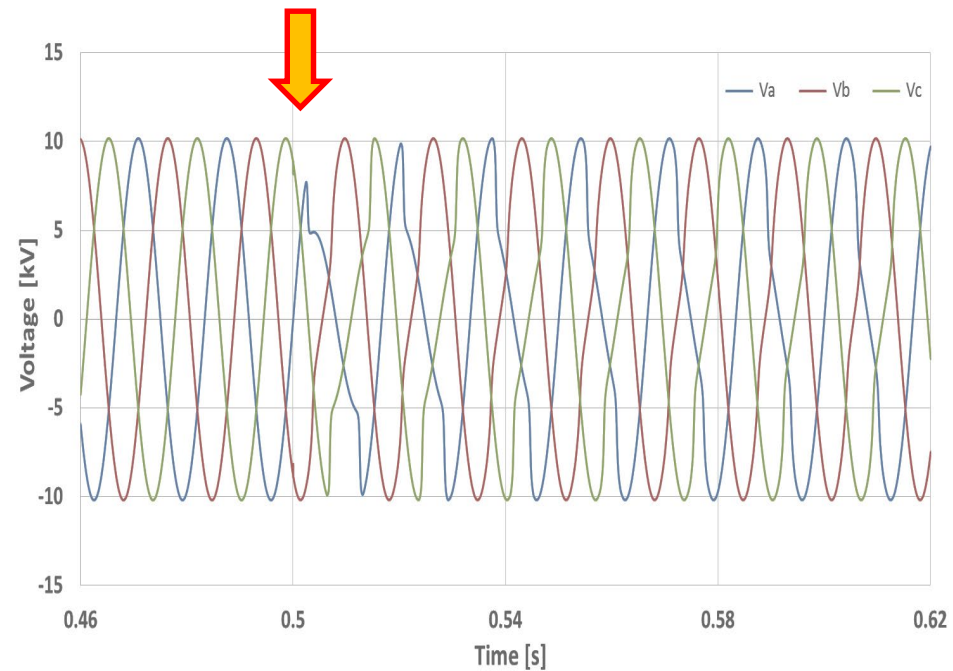

Transformer Inrush Current

Traditional Switching Device

No Residual flux

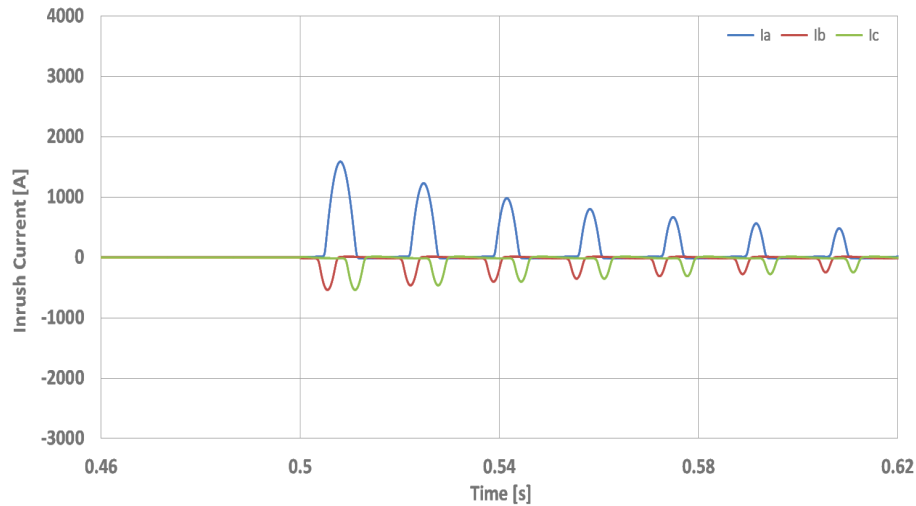

With Residual flux

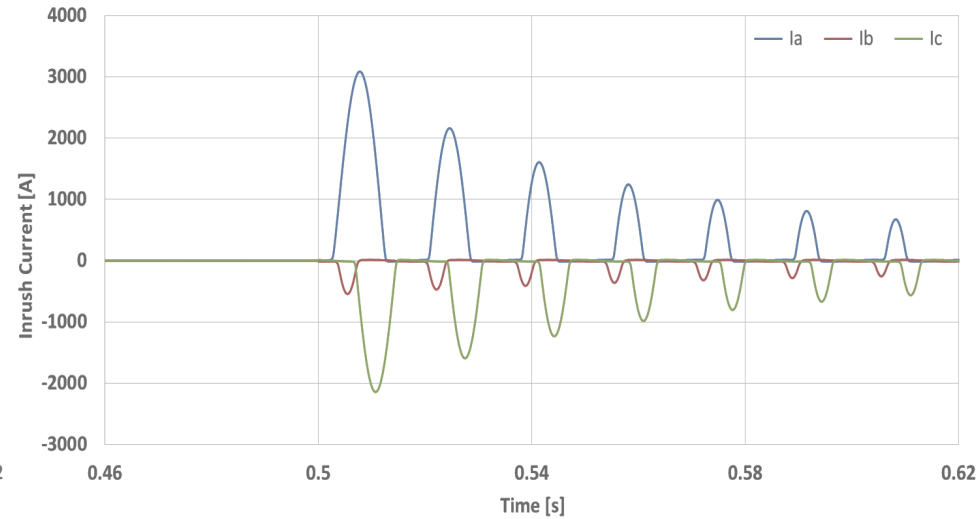

Transformer Voltage from Inrush Current

Traditional Switching Device

No Residual flux

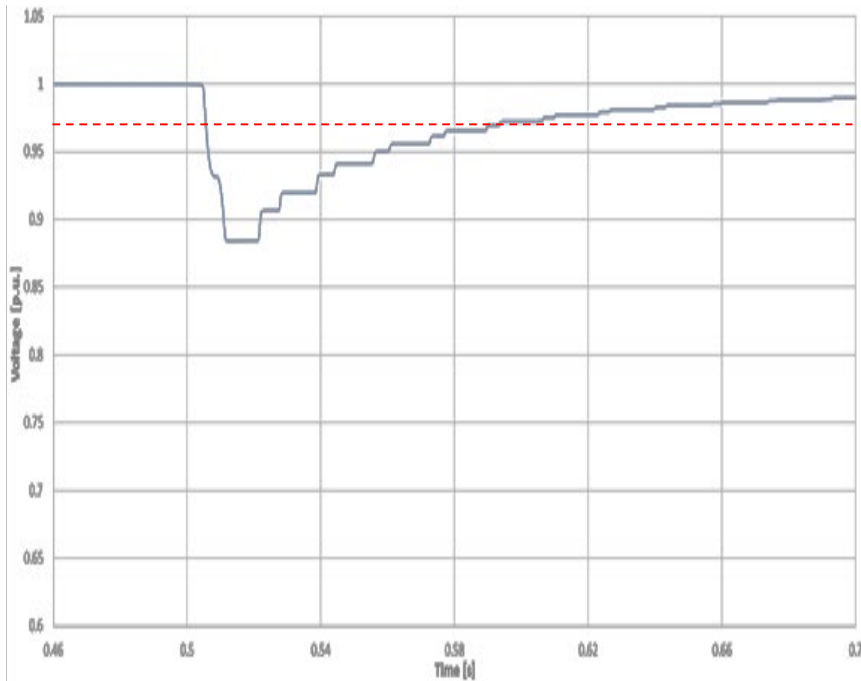

With Residual flux

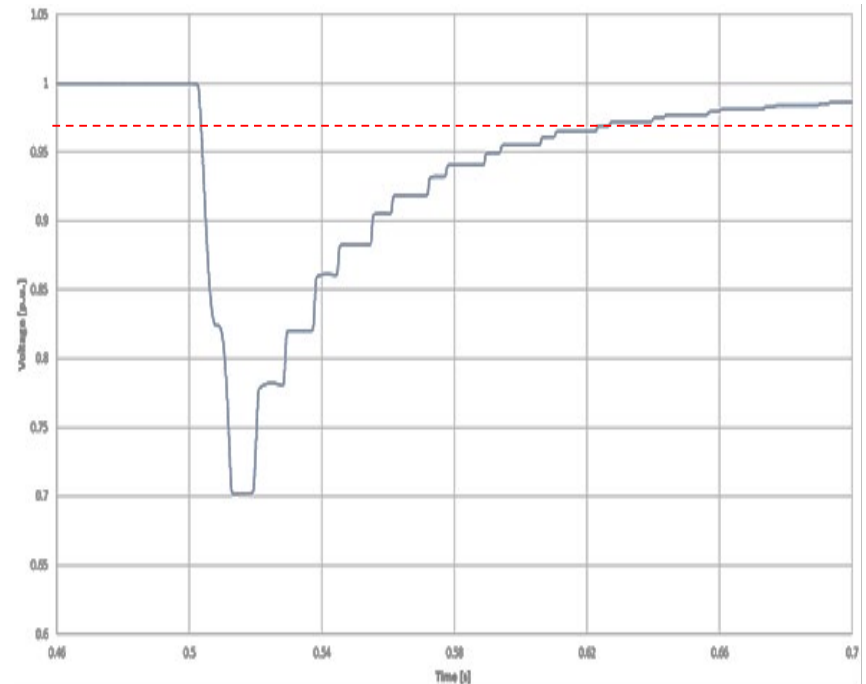

Inrush Current vs Resistor Insertion Time

Alternative Switching Device

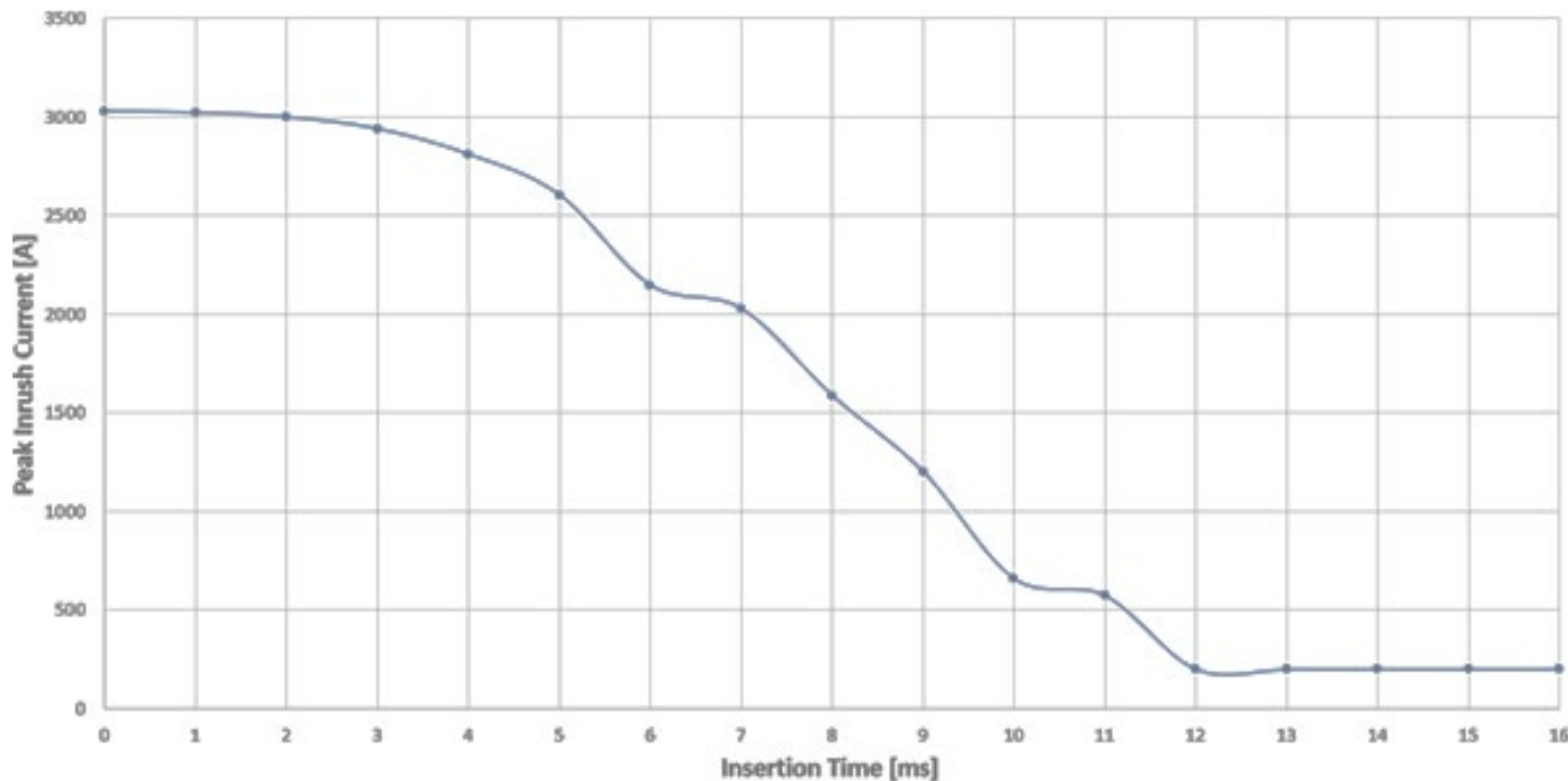

Transformer Inrush Voltage

Comparison of Switching Devices

Traditional with Residual Flux

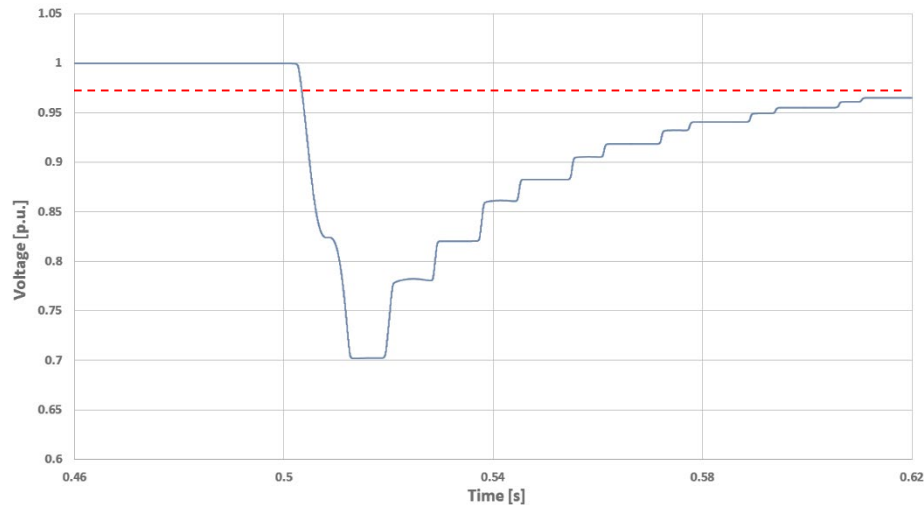

Pre-Insertion Resistor with Residual flux

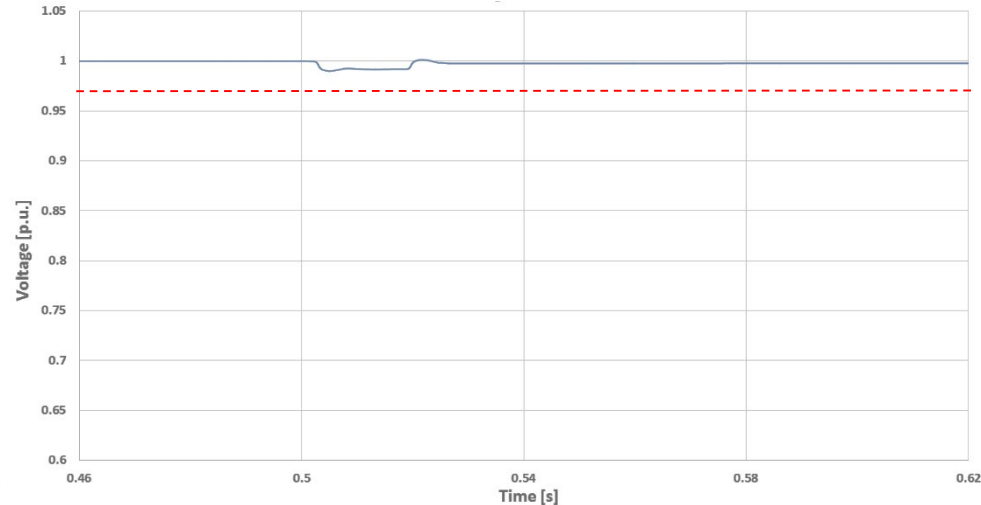

Transformer Inrush Current vs MVA

Traditional

Inrush vs. MVA
(by Circuit kA)

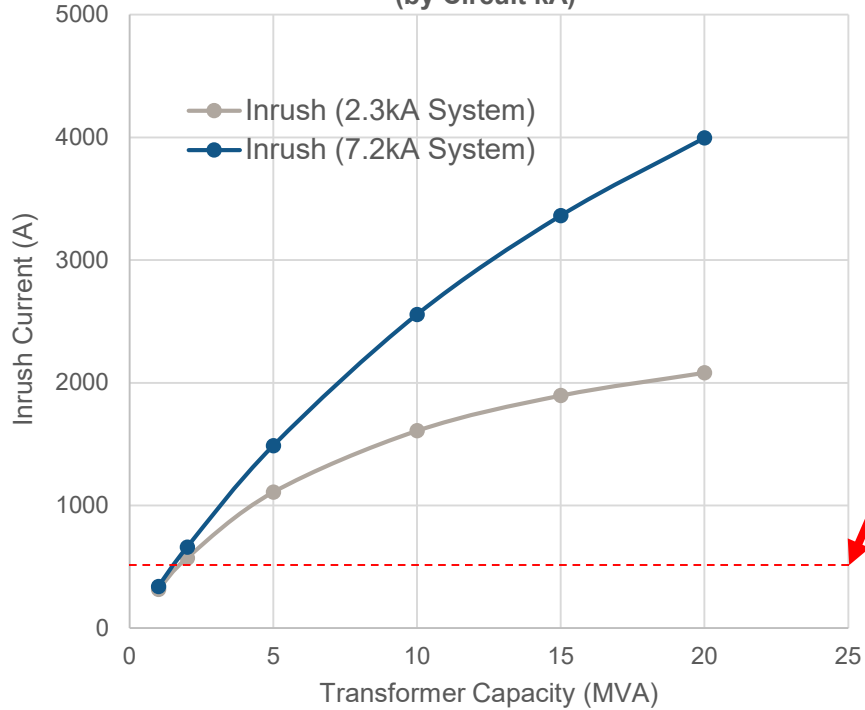

Alternative Pre-Insertion Resistor

Inrush vs MVA
Inrush Current Performance of 30Ω vs. 300Ω Resistor

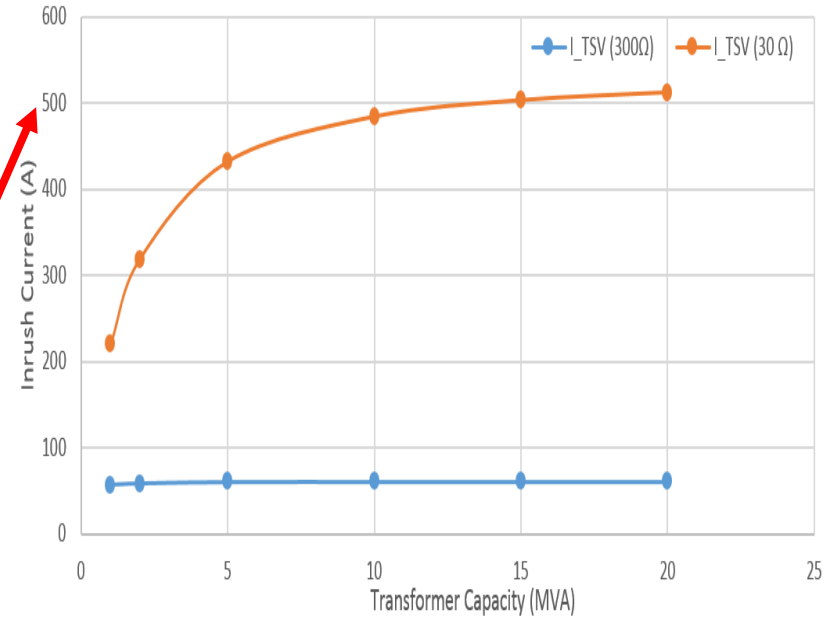

Transformer Inrush Voltage vs MVA

Traditional

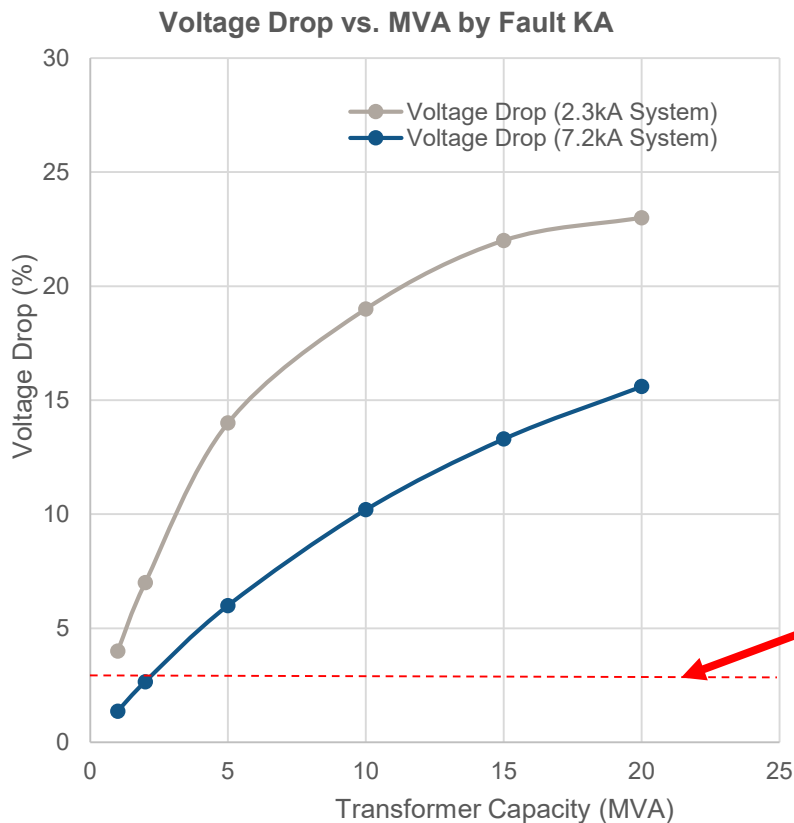

Alternative

Pre-Insertion Resistor with 30 ms Insertion Time

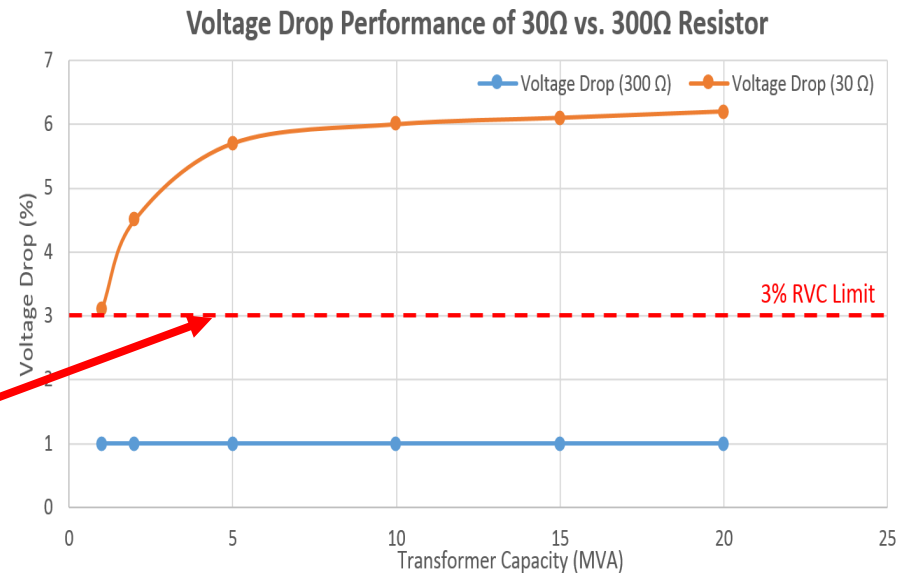

Summary and Conclusions

- Problematic Voltage dips due to Inrush Currents can be Controlled with properly applied Pre-Insertion Resistors:
 - Resistor Size and Insertion Time must be sized using local system parameters.
 - Point-On-Wave closing is not required
 - Reliable, mechanical design is not sensitive to environmental factors
 - Easy to Install, Low Maintenance
- Other Solutions Exist but are more complex:
 - IPO switching devices with.....
 - Point-On-Wave Controllers
 - Flux Sensing
 - De-Fluxing

One Solution Concept For All Voltages



Traditional with Residual Flux

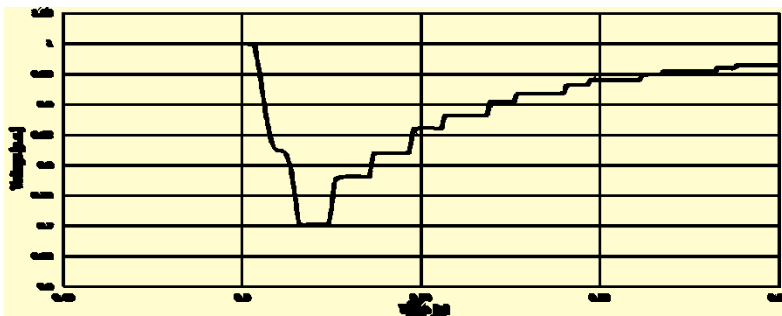

Pre-Insertion Resistor and Residual flux

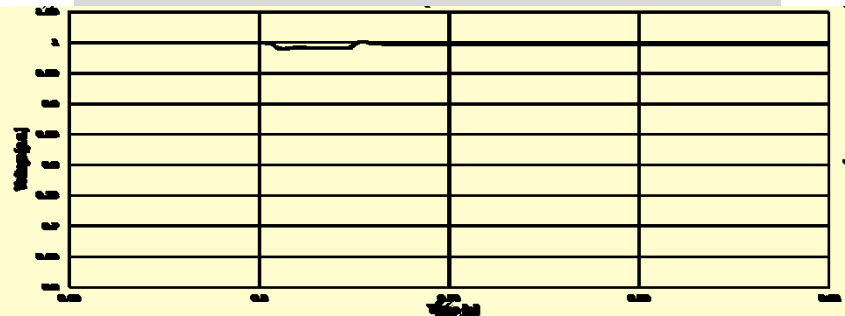

Questions ?

