

SOLID STATE POWER TRANSFORMATION

I. BACKGROUND...

I. BACKGROUND

- 1. Shift to wind and solar power will challenge today's transmission system architecture eventually requiring HVDC supergrids to support broad regional generation diversity.**
- 2. "Networking" of DC is a new game...one that will need the DC equivalent of an AC Transformer.**
- 3. One solution, the result of over 10 years of study and simulation: the "Multi-module DC Transformer, MMDCT*"**

** US and International patents pending*

An Apology....

- 1. The transformation configurations represented in figures 2, 3, and 4 of the paper, while achievable, are more complex and may be less useful than implied.**
 - 2. That said, the likelihood of a cost-competitive basic, solid-state AC-to-AC transformer are probably real.**
- The later will be the focus of this presentation**

MMDCT Operating Cycle

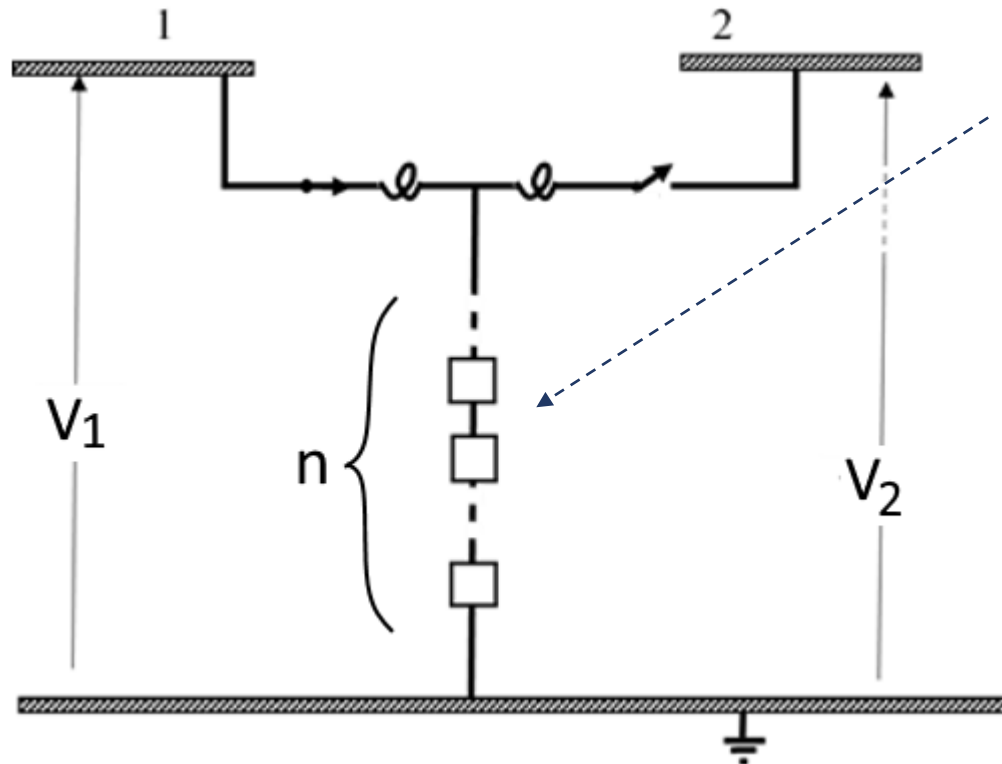

A capacitor column of n modules...each capable of being:

- 1. Inserted into the series column...or*

MMDCT Operating Cycle

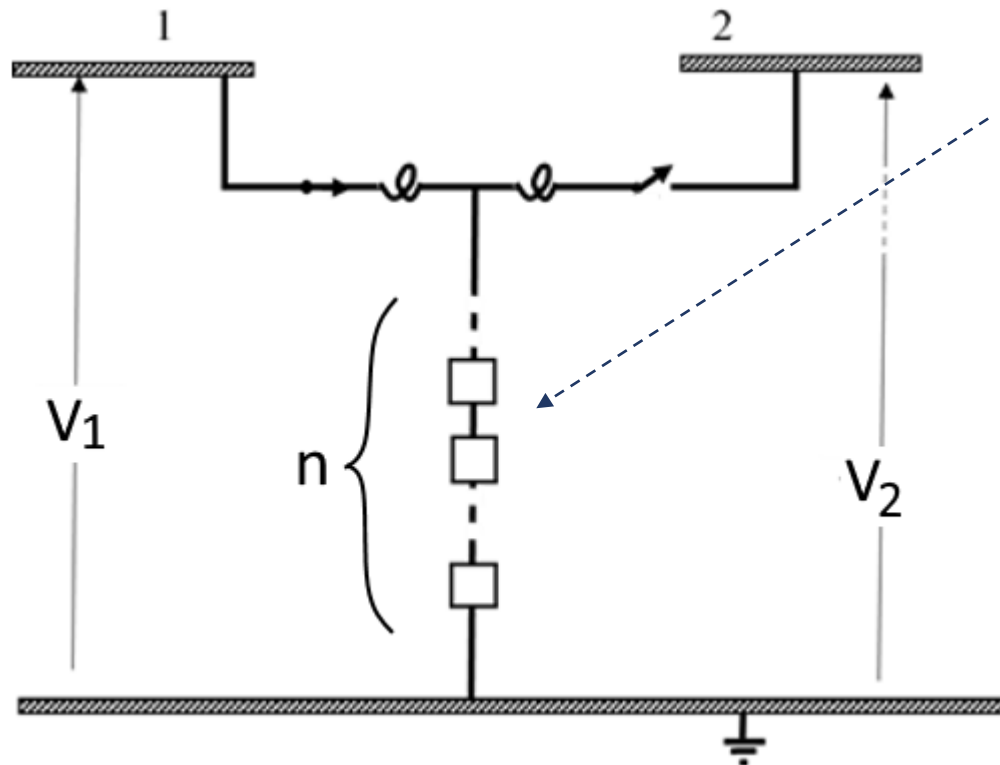

A capacitor column of n modules...each capable of being:

- 1. Inserted into the series column... or*
- 2. Electrically bypassed ...or*

MMDCT Operating Cycle

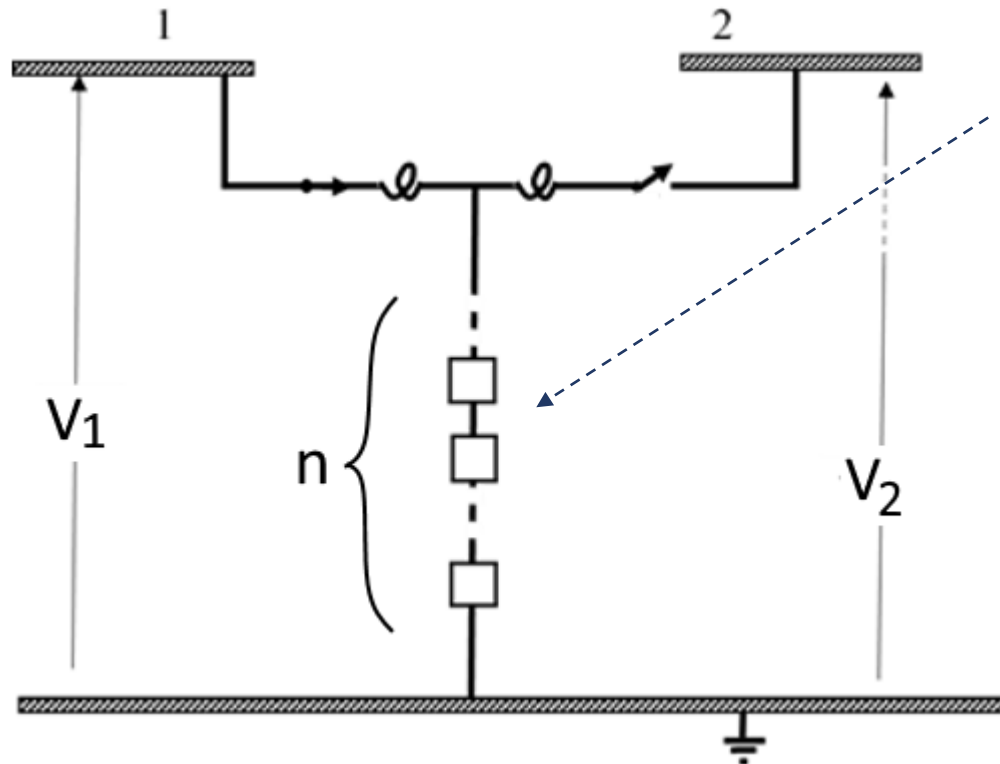

A capacitor column of n modules...each capable of being:

- 1. Inserted into the series column...or*
- 2. Electrically bypassed ...or*
- 3. If "full" modules... removed from the column, reversed in polarity...then reinserted into the column.*

MMDCT Operating Cycle

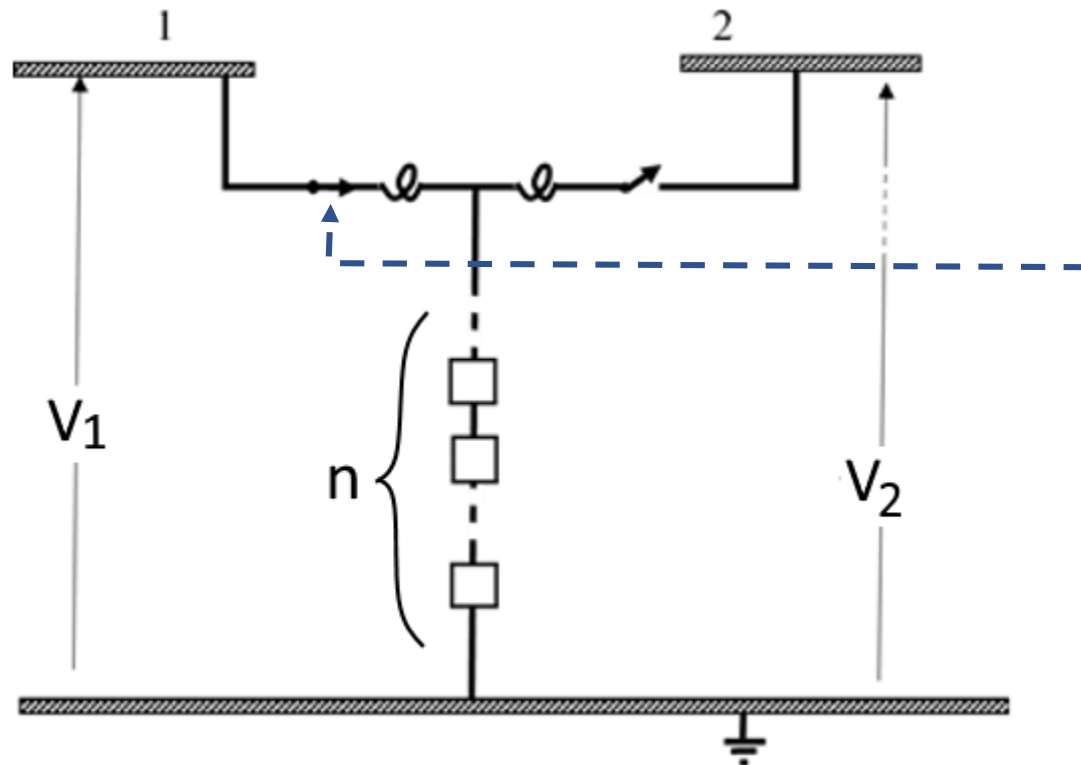

A repeating three-step cycle:

1. Column with all n modules in series is resonantly charged from the primary bus 1

MMDCT Operating Cycle

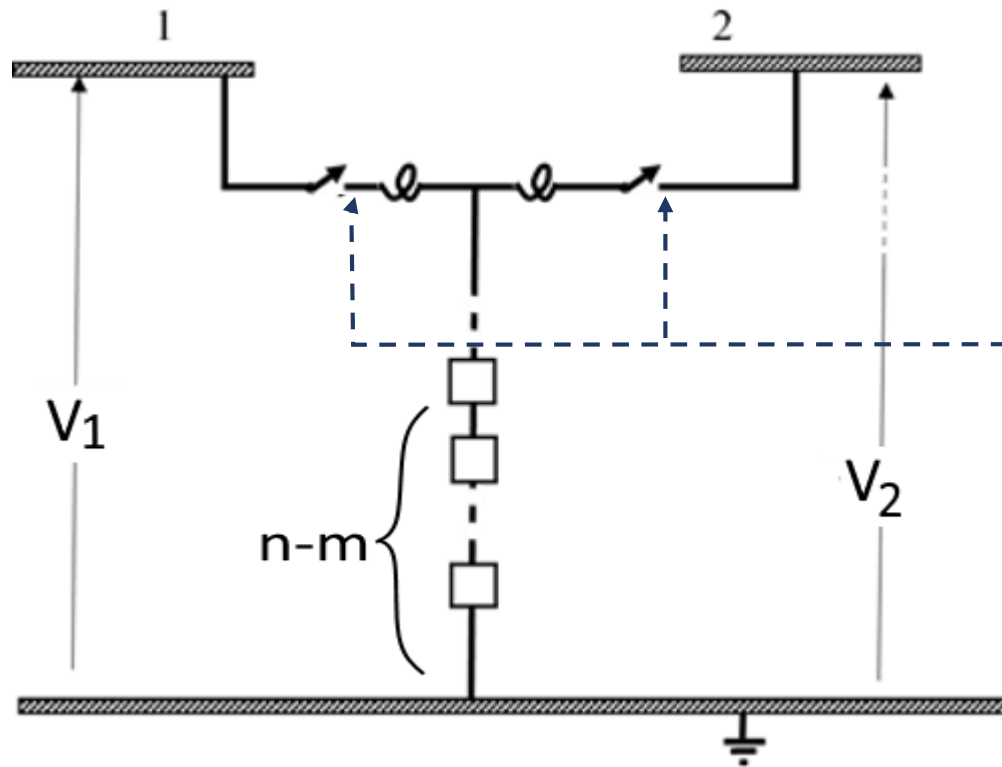

A repeating three-step cycle:

1. Column with all n modules in series is resonantly charged from the primary bus 1
2. Column is isolated and m of the n modules are isolated and bypassed

MMDCT Operating Cycle

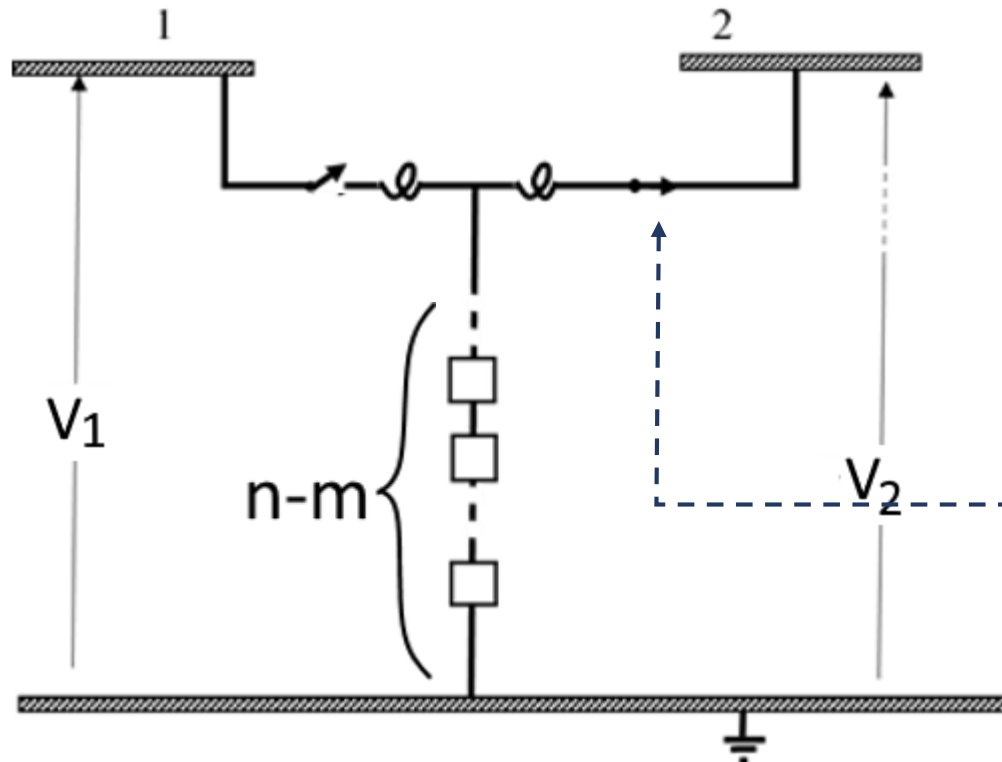

A repeating three-step cycle:

1. Column with all n modules in series is resonantly charged from the primary bus 1
2. Column is isolated and m of the n modules are isolated and bypassed
3. Secondary switch is closed to exchange charge with the primary bus with $n-m$ modules in series

The process is then repeated.. The voltage ratio being $n/(n-m)$

MMDCT Operating Cycle

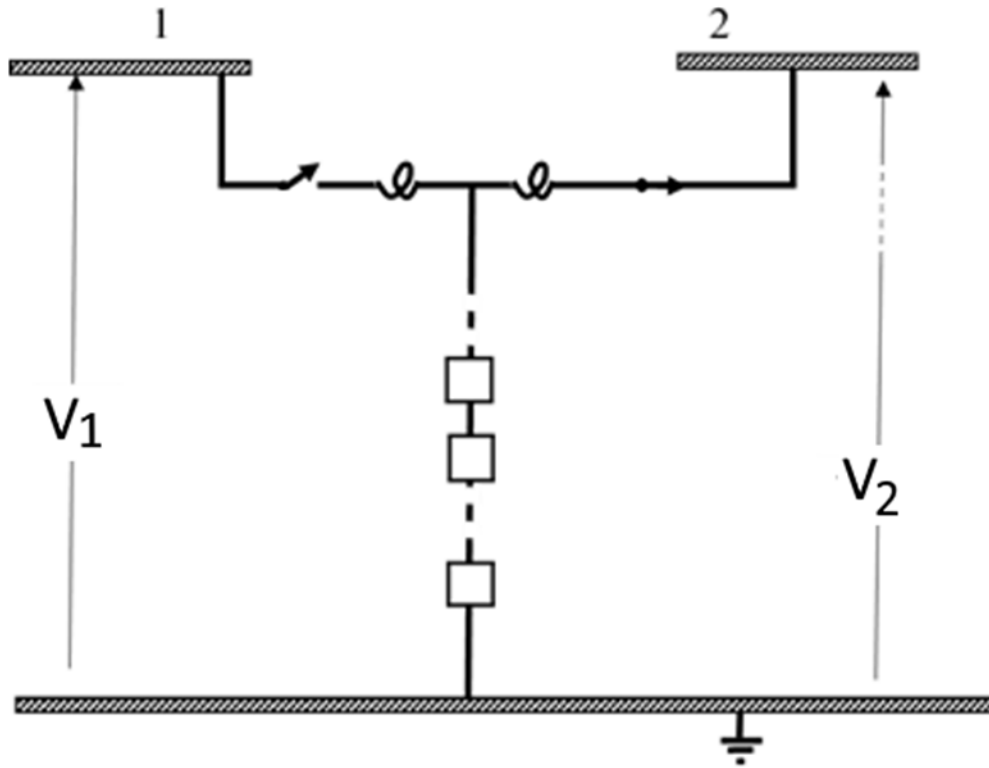

It would seem that capacitors discharging to secondary would be left with lower charge than others!

“Sorting” avoids that by letting all n capacitors take an equal time in the n group.

The process is then repeated.

... Input and output wave forms

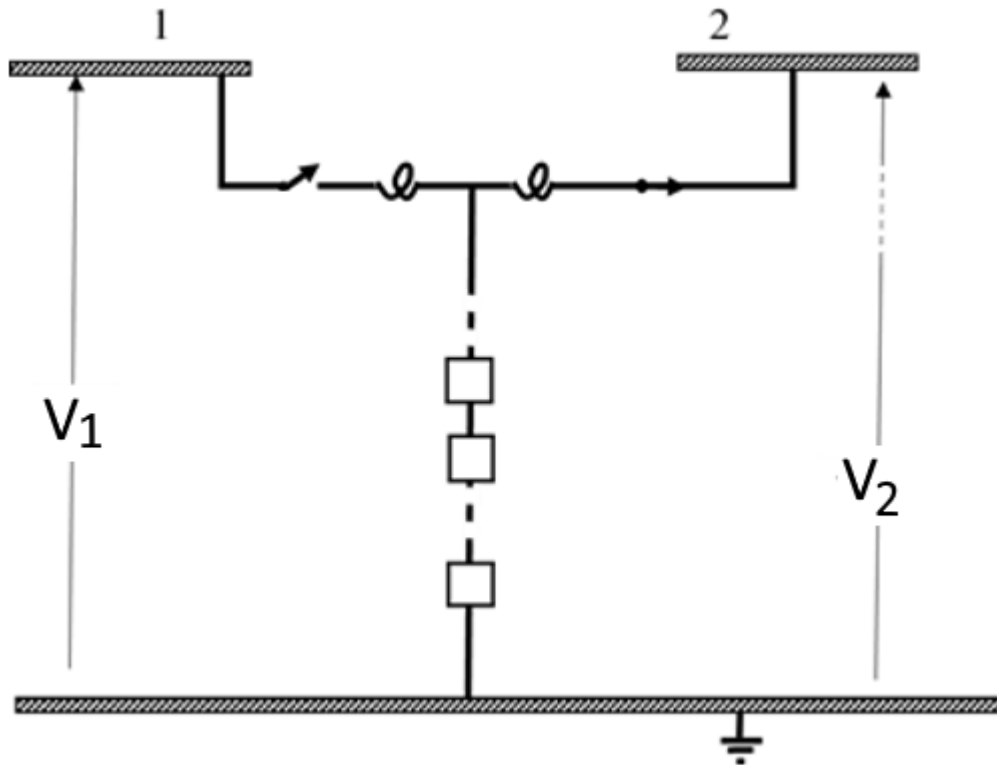

Input Current

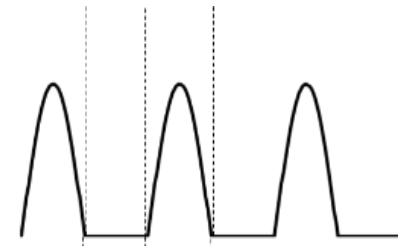

Output Current

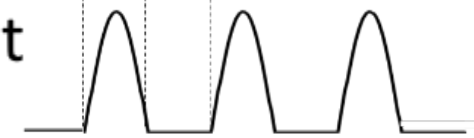

.... Smoothed by input and output capacitors

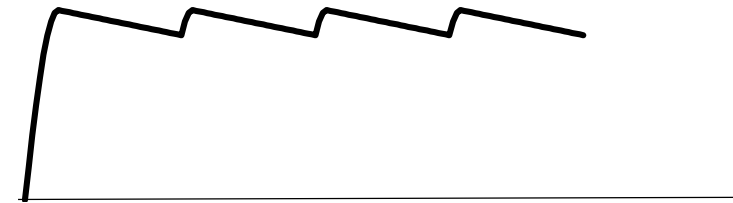
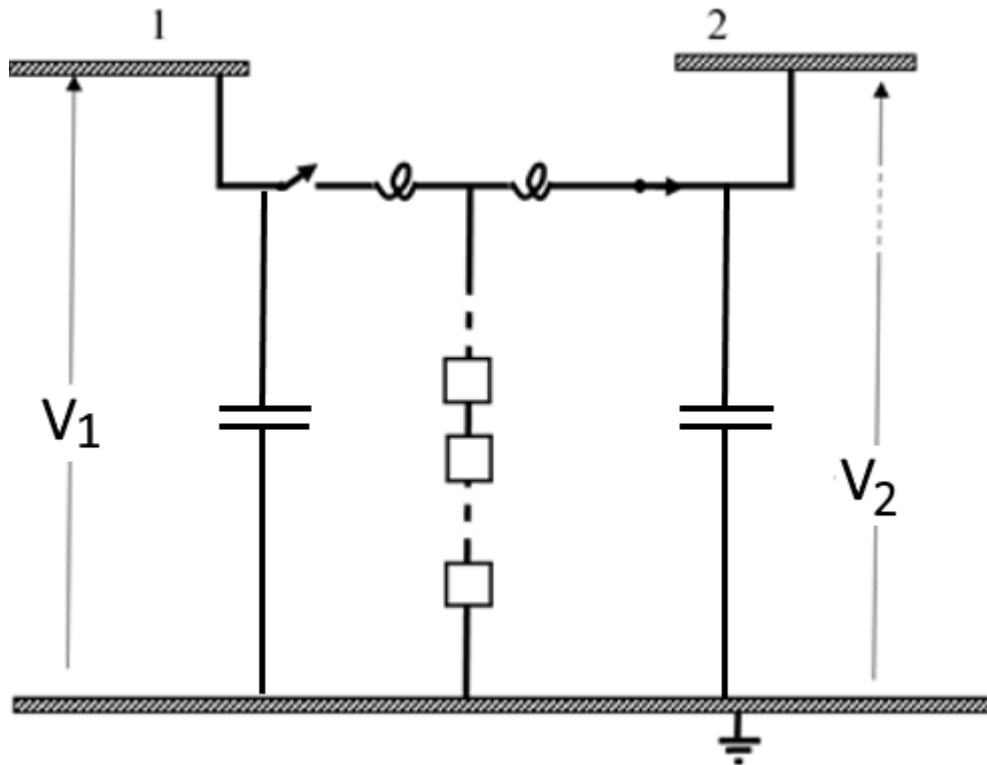

Nature of input and output current waveform

... Or used in triplicate...also tripling MW rating.

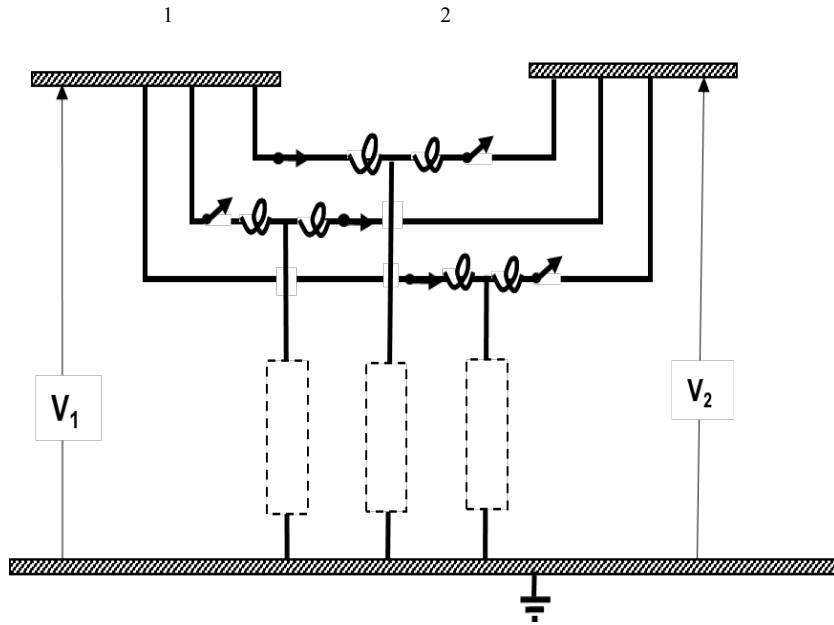

Input & Output Current Waveform

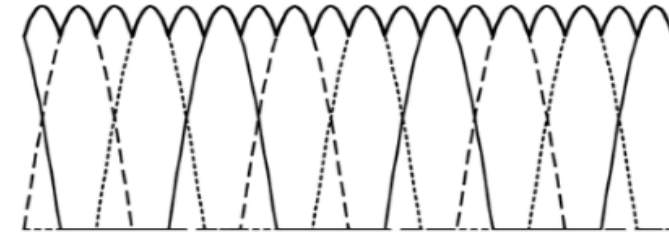

Easily Adapted to Various Grounding and Commutation Systems

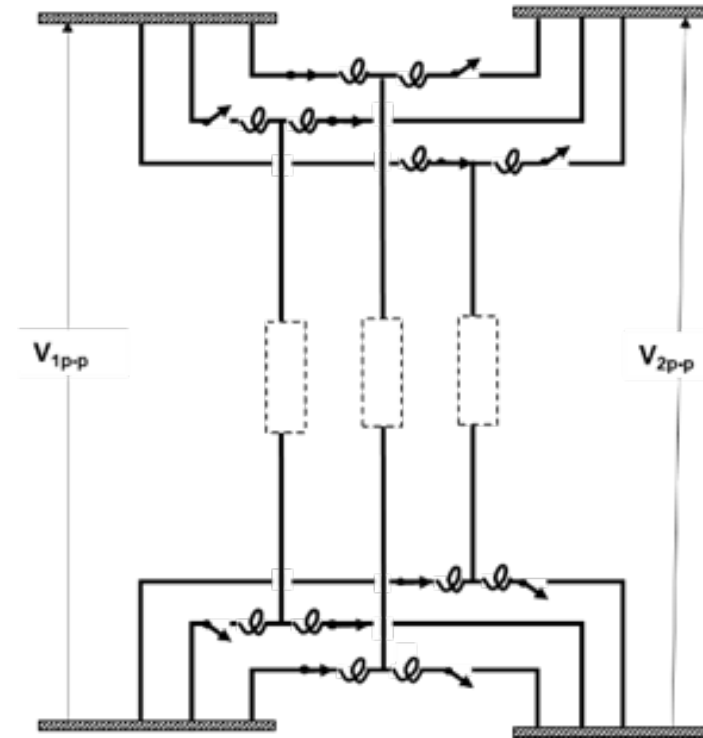
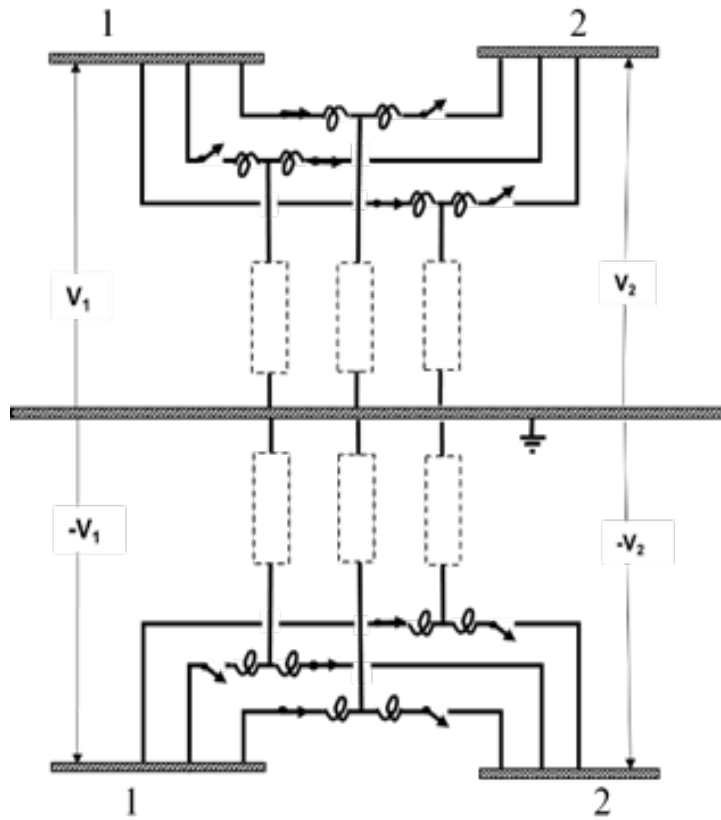

EXAMPLE MMDCT ADVANTAGE:

DC/AC INTERFACE USING EXISTING TECHNOLOGY

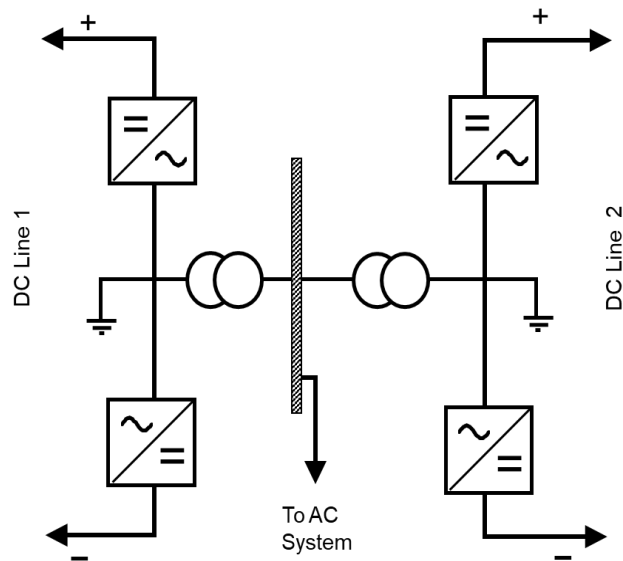

- Double transformation of through DC power flow
- Need 2 magnetic Transformers

EXAMPLE MMDCT ADVANTAGE:

DC/AC INTERFACE USING MMDCT*

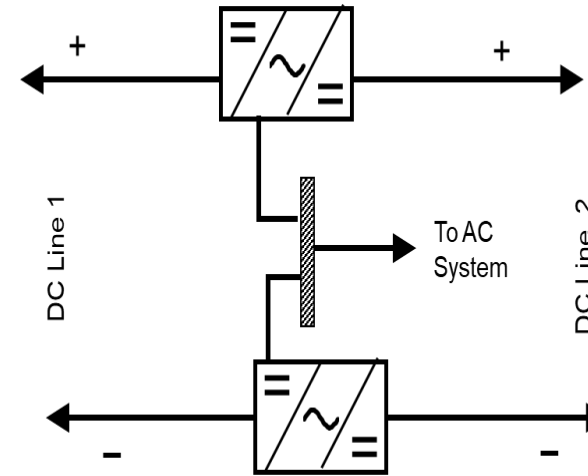
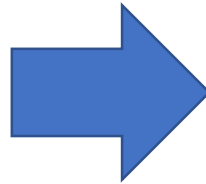
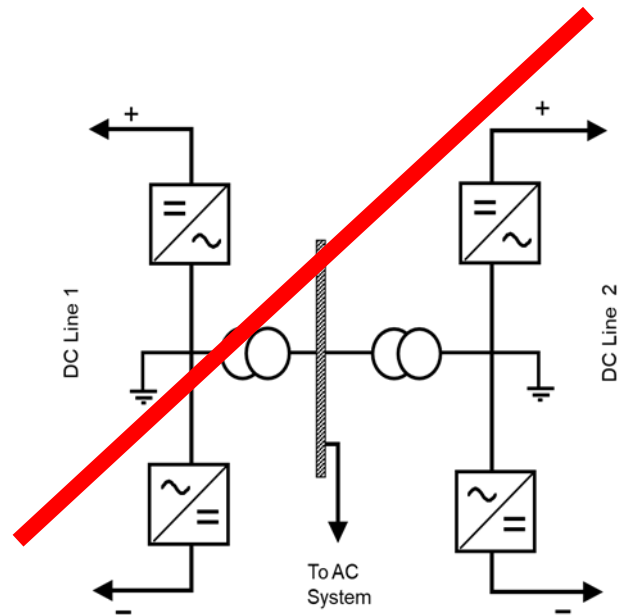

** Linking DC Macrogrids to Underlying AC Systems. Cigre Paper B4-103 Paris, 2018*

- **Direct transformation of through DC Power**
- **No magnetic Transformers**

II . EXTENDED APPLICATIONS

The “MMDCT” will work for any input/output voltage wave shape

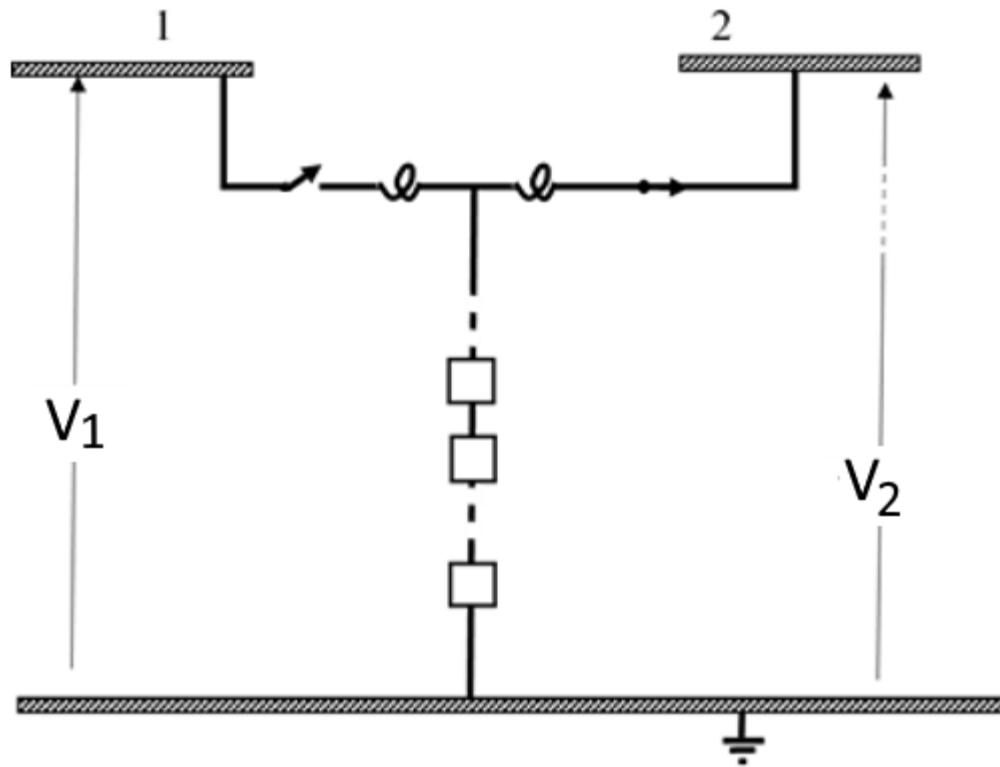

...e.g. 60 Hz AC !

The “~~MMDC~~T” will work for any input/output voltage wave shape

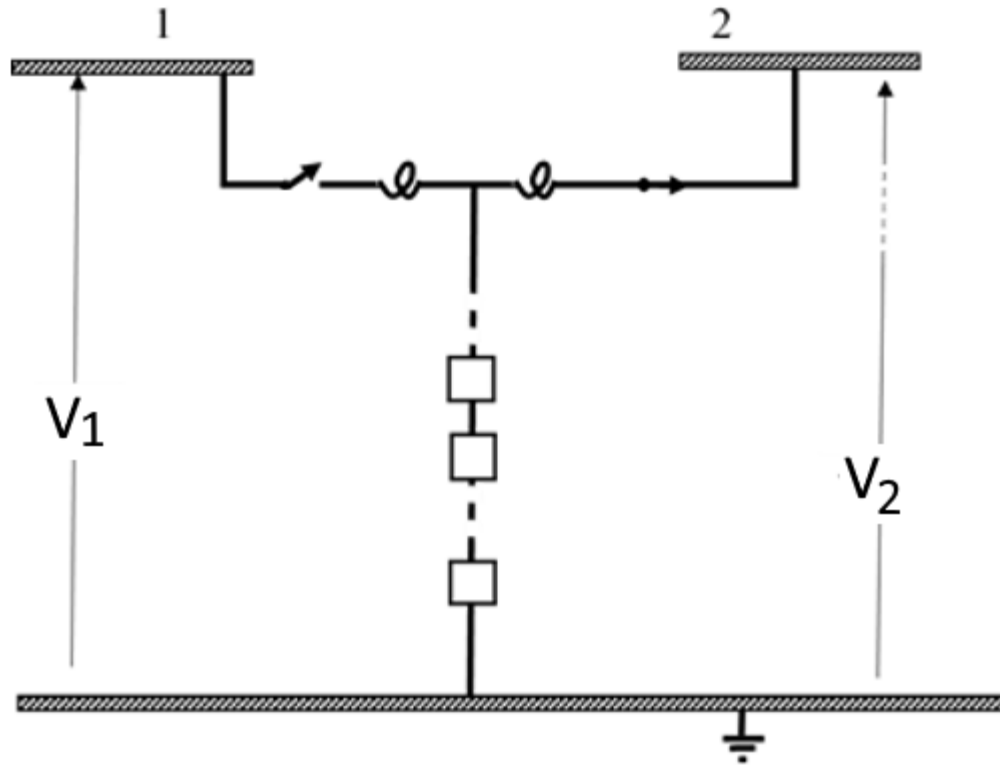

...e.g. 60 Hz AC !

Smaller, Cheaper, Solid-State AC Transformers?

1. **Size & Cost of the MMDCT (DC or AC) is proportional to capacitor ufds (Columns and output smoothing) & solid-state switches**
2. **Capacitor ratings are inversely proportional to frequency**
3. **Past assumption: Maximum of 2.5 kC**
4. **Silicon Carbide IGBT's? 10 to 20 kC ... 4 to 8 times higher!**

Perhaps re-think the basic transformer function.

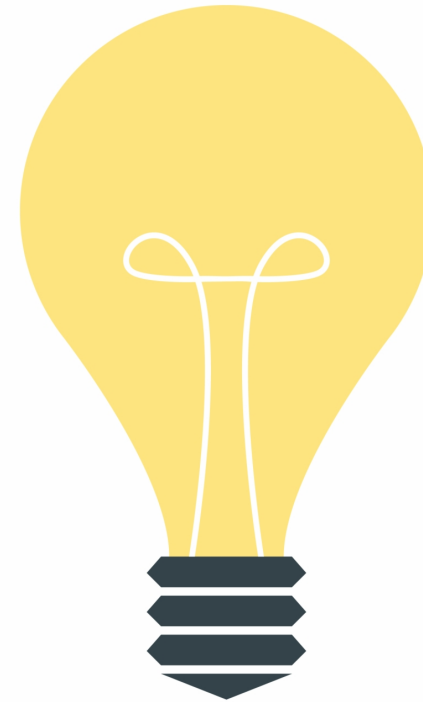

Classical Transformation Principle:

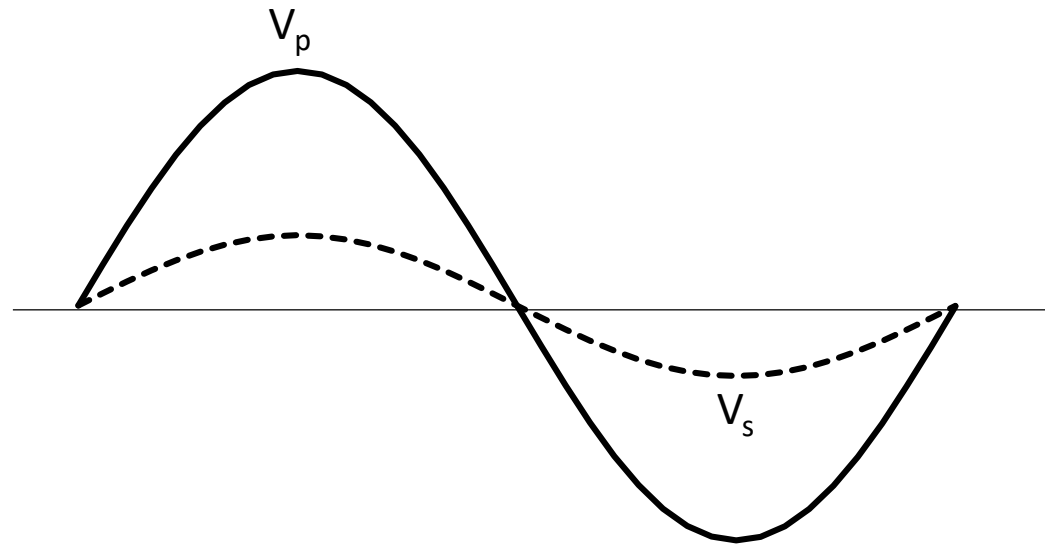
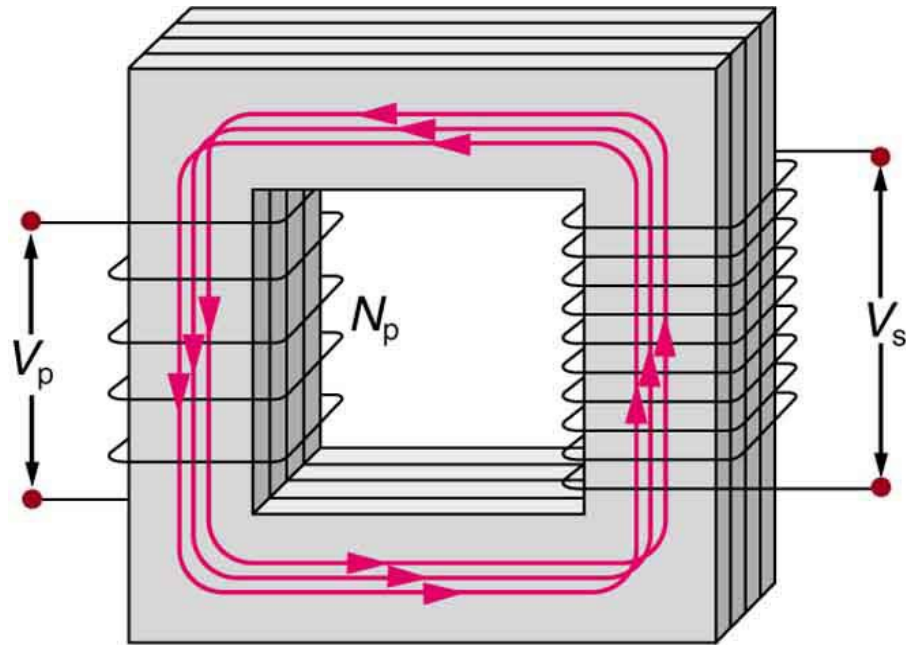

.... A continuous Process!

Why not an incremental, bit-wise Process?

One that can accommodate any primary and secondary voltage profile!

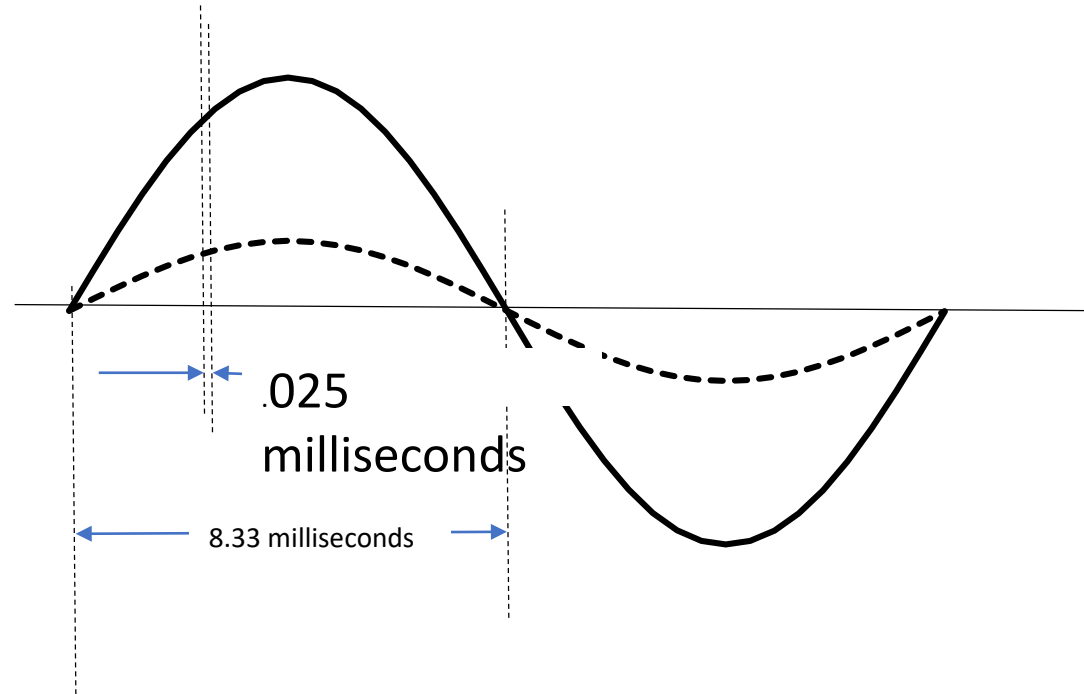

Incremental Transformation Principle:

Works simplest if input and output wave shapes remain proportional (AC-to-AC or DC-to-DC)ratio of input to output energy is equal for each time increment.

.... the role of today's magnetic transformers

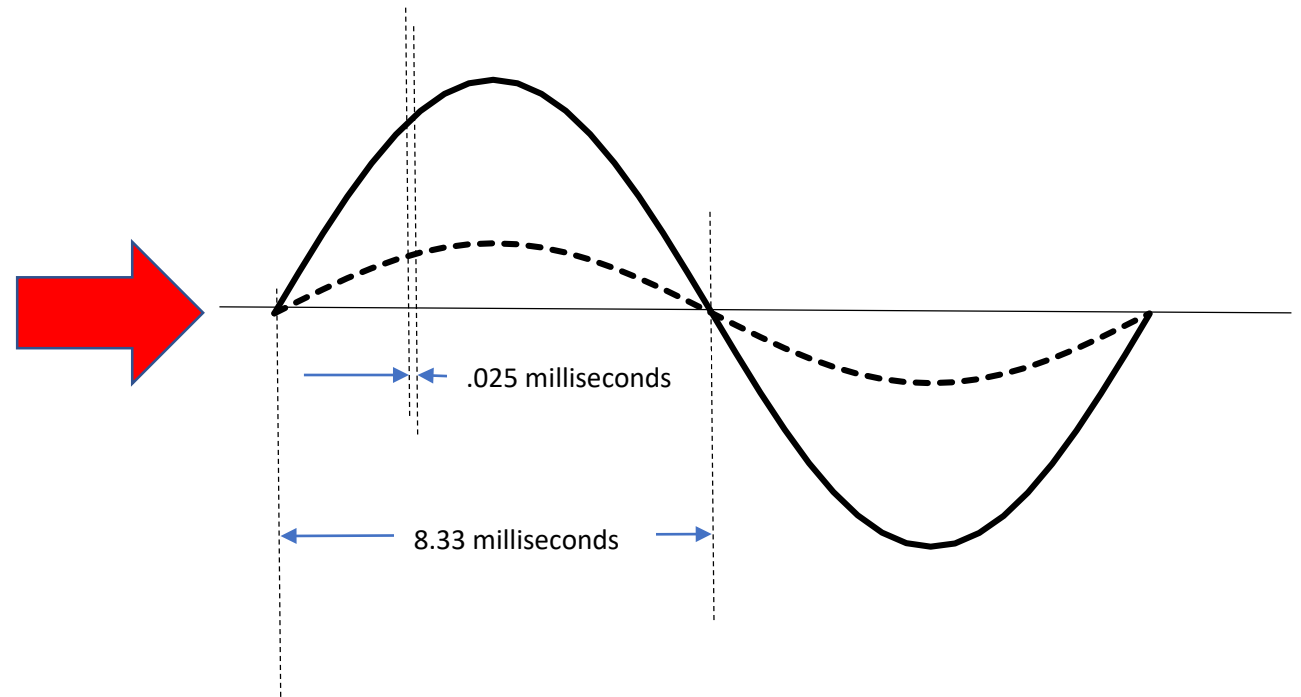

Incremental Transformation Principle:

Where wave shapes differ... e.g.

1. AC to DC
2. AC phase shift
3. 50 Hz to 60 Hz

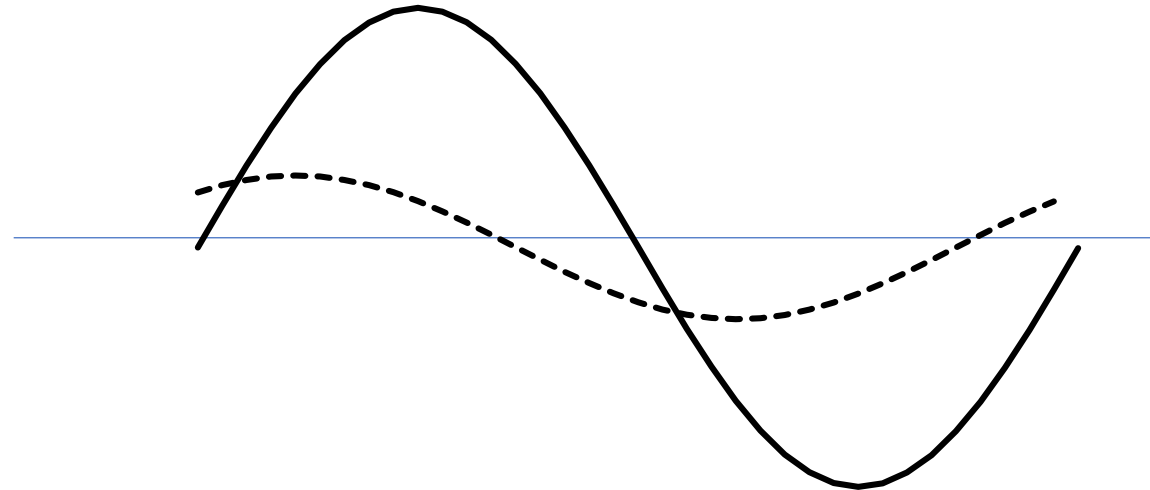
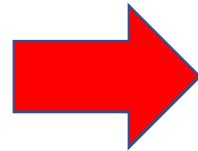

A Provision for inter-cycle storage is needed

....Either within the capacitor column or in an external capacitor

Fundamental question...

Can solid state technology replace magnetic technology for basic AC-to-AC power transformation?

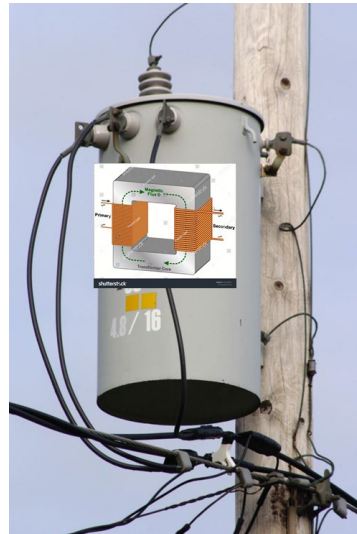

Prospect for shifts to solid state Transformers:

	Magnetic	Solid State
Technology	Mature	Evolving

Prospect for shifts to solid state Transformers:

	Magnetic	Solid State
Technology	Mature	Evolving
Functionality	Limited	Extended*

- * **1. Fault Isolation**
- 2. No spare**
- 3. No circuit breakers**
- 4. No oil...less env. risk**
- 5. Modular Manufacture**
- 6. Easy Ratio Adjustment**

Prospect for shifts to solid state Transformers:

	Magnetic	Solid State
Technology	Mature	Evolving
Functionality	Limited	Extended
Cost	Escalating	Dropping

Prospect for shifts to solid state Transformers:

	Magnetic	Solid State
Technology	Mature	Evolving
Functionality	Limited	Extended*

- * **1. Fault Isolation**
2. No spare
3. No circuit breakers
4. No oil...less env. risk
5. Modular Manufacture
6. Easy Ratio Adjustment

6. Phase Shifting
7. AC + DC Secondaries
6. Reactive Power Source or Sink
7. Frequency Transformation

3. Historic Transitions in Technology...

Fisher-Pry Model (1971)

Beginning with the shift from wood to coal for heating, changes in technologies have been driven by convenience or operating features....not cost!

It could happen in your lifetime!

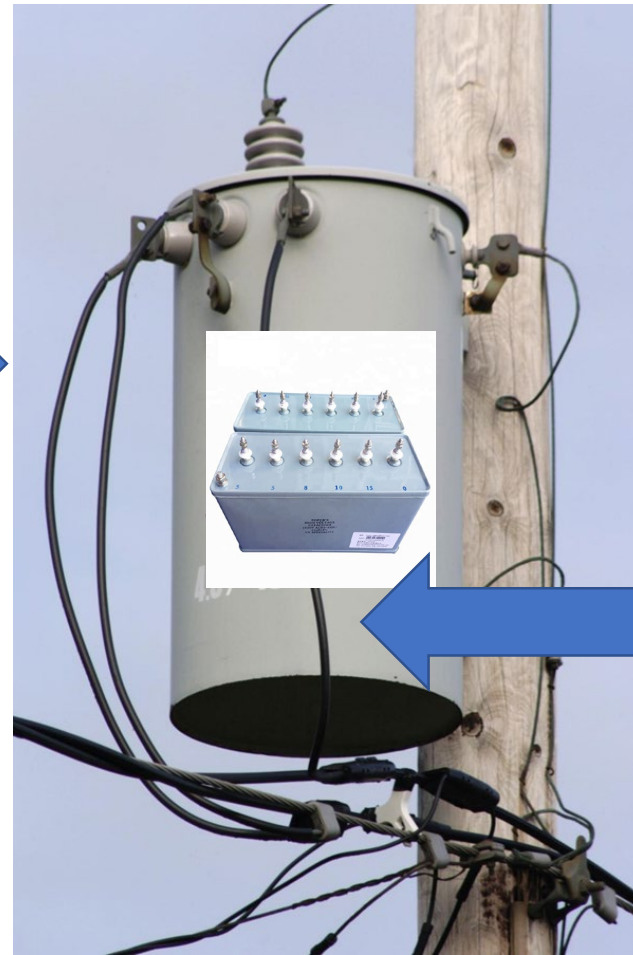
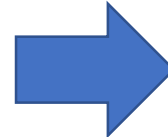
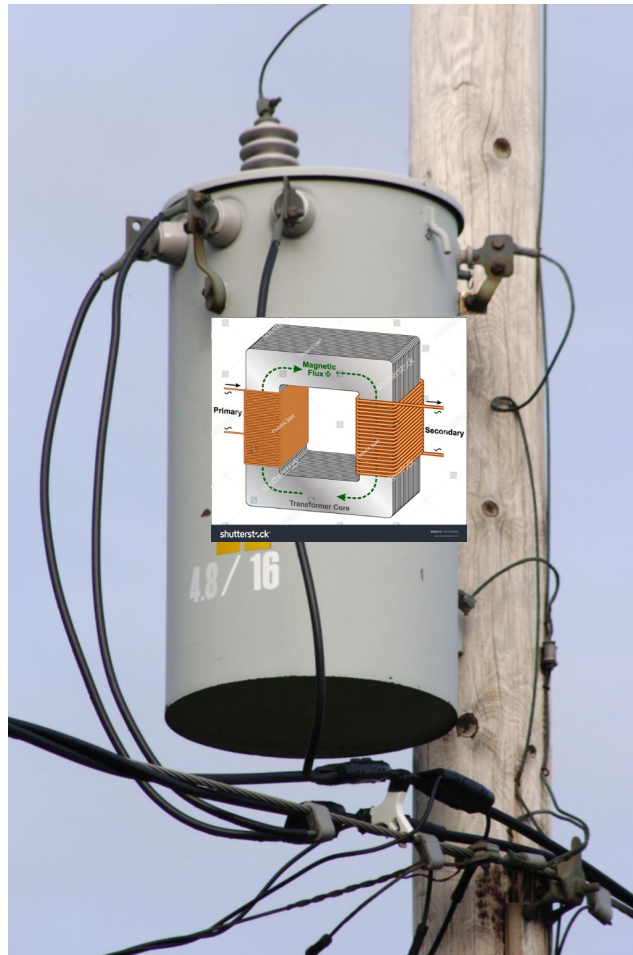

**Maybe DC bushings
too...for auto
charging**