



21, rue d'Artois, F-75008 PARIS  
<http://www.cigre.org>

## CIGRE US National Committee 2018 Grid of the Future Symposium

### **Cable Train: In-Situ Manufacturing of Trackside Underground Cable HVDC Transmission Systems**

**L. A. GRAY Q. DU A. H. SLOCUM**  
**Massachusetts Institute of Technology**  
**USA**

#### **SUMMARY**

High Voltage Direct Current (HVDC) transmission can offer low energy losses over long distances, allows for the linkage of incompatible AC grids, exhibits superior controllability, requires less right of way (ROW), and may be less vulnerable to geomagnetically induced currents (GICs) and aggressive EMP attacks, than AC systems. In the grid of the future, HVDC assets will likely be the technology of choice in many scenarios, especially for low loss, long-distance power transmission from remote renewable energy sources. Currently, overhead lines (OHL) are much lower cost than underground cables (UGC); however, OHLs are vulnerable to damage from the environment, require larger ROWs, produce significant external magnetic fields (EMFs), and create substantial visual pollution, which has resulted in significant public opposition and lengthy delays in project permitting. In an attempt to close the cost gap between UGC and OHL, we propose the co-location of UGC systems alongside railroad tracks. The increased mobility of machines, materials, and workers on railroads may make the installation and maintenance of “trackside UGC” considerably less than conventional UGC. The use of private railways may also avoid conflicts with external stakeholders and reduce the regulatory delays that have plagued many renewable energy transmission projects. Additionally, taking full advantage of the increased accessibility and load capacity capability of railroads by in-situ manufacturing high voltage cable in lengths far greater than what is currently transportable by road haulage, could lower overall project costs by greatly reducing expensive and vulnerable cable splices. We present a proof-of-concept method for continuously manufacturing and installing high voltage UGC from a moving “Cable Train.” There are three primary challenges associated with such a manufacturing platform – extrusion, curing, and degassing, which can be addressed by continuous extrusion, horizontal curing, and inline degassing, respectively. Of particular interest is an enabling design for a space-saving, inline degassing system. Lifetime and total build cost estimates are performed and results are compared with past projects.

#### **KEYWORDS**

Cable Train, trackside UGC, cable splice, underground cable, continuous cable, HVDC, inline degassing

## Background

Resolutions to decarbonize energy consumption have been on the rise during the last decade. California and Massachusetts, for example, have both committed to ambitious renewables development plans. The former has promised to reduce greenhouse gas emissions by 40% below 1990 levels by 2030 (SB 350) and the latter has promised to achieve 100% de-carbonization by 2050 (An Act Relative to Energy Diversity) [1], [2]. This evolution in energy portfolios requires the utilization of new, and often remote, renewable energy resources. In the U.S., solar and wind resources are highly concentrated in the southwest and central regions of the country [3], [4], and lack of grid accessibility is often cited as a barrier to a more rapid transition to renewable energy dependence.

High Voltage Direct Current (HVDC) transmission has become the technology of choice in many scenarios, especially for long-distance transmission, and will be vital for the growth of the renewable grid. Over long distances, the cost of HVDC converter stations is offset by the elimination of capacitive, inductive, skin effect, and dielectric charging losses as well as intermediate reactive power compensation requirements associated with long-distance HVAC. This leads to a break-even distance where HVDC becomes less costly than HVAC. HVDC connections also allow AC grids operating with different frequencies or phase to efficiently exchange power. HVDC systems require less material and narrower right of ways compared to 3-phase AC systems. It has also been suggested that voltage source controlled (VSC) HVDC systems may be more robust to geomagnetically induced currents (GICs) [5].

Because of the intermittent and off-demand generation of renewable plants, the economics of a cost-competitive renewable grid are difficult to model. Without sufficient storage potential, building a grid that can allow high penetration of renewable energy, with little or no increase in the cost of electricity, is a problem many are trying to solve. In 2016, a study by NOAA scientists found that a large-scale, optimized HVDC grid could enable the U.S. to use wind and solar generation to eliminate up to 80% of CO<sub>2</sub> emissions while meeting its energy needs at the same cost of electricity as in 2012 [6].

Because the best renewable resources in the U.S. are land-locked, developers will be unable to use benefits afforded by the technical maturity of cable laying vessels (CLVs), which has been exploited to install a large HVDC network in northern Europe. For over-land transmission, developers have historically opted to use overhead lines (OHLs) because they are, on paper, several times cheaper than underground cables (UGCs), four to fourteen times according to one report [7]. Despite this economic advantage, the visual pollution caused by, and wider right of ways (ROW) required by, OHLs have sparked stakeholder objection, leading to costly, and sometimes fatal, project delays. UGCs are essentially invisible, they are less vulnerable to damage, exhibit lower transmission losses, and reduce or eliminate ambient magnetic and electric fields. The development of cheaper UGC systems may also be able to significantly streamline regulatory review and increase the speed at which vital HVDC links are constructed.

## 2. Symbiotic approach: co-location of HVDC links and railroad corridors

UGC is significantly larger in diameter than unshielded OHL. Hence, for land-based systems, cable bending limits and transportation weight limits restrict the length of HVDC cable that can be spooled at the factory and transported to the installation site. Installation lengths are usually limited to about 1.5 km. This leads to a costly, piecemeal construction process wherein cables are joined by cable splices, located in splice pits, that have been prone to failure and costly to repair [8].

As proven by submarine cable manufacturing, is it possible to manufacture extremely long lengths of cable (20-30km), void of any joints, using carefully synchronized manufacturing [9]. We hypothesize that the cost of UGC systems can be significantly reduced via the co-location of cable and existing railroad corridors, or “trackside UGC” that also utilizes railroads to implement very long cable lengths.

Figure 1 shows the enormous network of railroad corridors in the U.S., which could host large portions of a future HVDC grid. Railroads make the transport of machines, materials, and personnel far less costly and increased accessibility will reduce capital cost and overall lifetime cost compared to cable buried, using off-road machines, in dedicated corridors. If cable is not in-situ manufactured in a continuous length, as is discussed shortly, railroads could still be used to deliver longer lengths of cable from a railcar, using reels or other packing methods. In addition, trackside UGC bears several advantages that are hard to assign a dollar value to, like streamlined project planning and regulatory review.

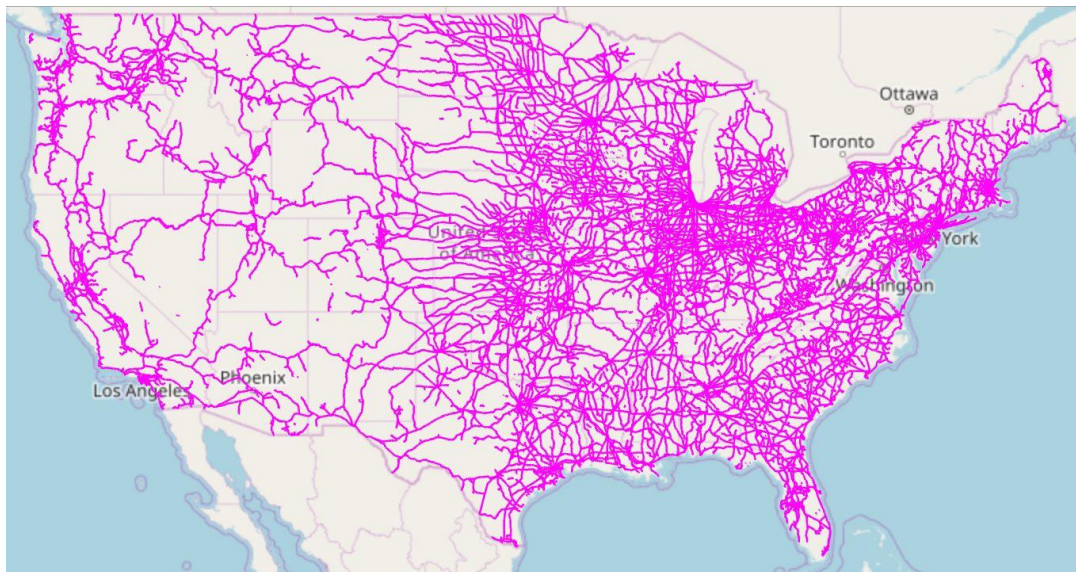

**Figure 1:** A map of known U.S. railroads constructed from GIS data.<sup>1</sup>

### *2.1 The case for trackside UGC, not OHL*

Since the 1980s, railroads have accommodated and maintained underground fiber optic networks. Union Pacific, for example, maintains over 34,000 miles of trackside fiber optic cable [10]. Rolling stock machinery exists that simultaneously plows through soil and lays fiber optic or signaling cable, which is dispensed from reels on the train, by threading cable through the plow itself [11].

Naturally, the idea of co-locating other utility services with railroads, including power transmission, is not unheard of, and many OHL lines share a right of way with railroads in the U.S. However, there are many points of incompatibility between OHL and railroads. A number of utilities have moved pre-existing “trackside OHL” out of railroad corridors in order to improve system reliability and worker safety. The United Illuminating Company removed 100-year-old trackside structures on the Metro-North Railroad (MNR), in Connecticut, and replaced them with independent, upgraded 115kV lines, using taller, galvanized, steel monopoles [12].

The Electric Power Research Institute (EPRI) sponsored research in 1977 investigating the possible deleterious effects of OHL transmission systems’ inductive potential on railroad communication and signaling [13]. Later research from 1986 investigated mitigation strategies to reduce the measured voltage and current induced in pipelines, rails, and signal conductors in a specific case study [14]. More recent research acknowledges that, while there are many mitigation strategies, it is difficult to design an overhead transmission system that is completely free from electromagnetic coupling between services [15]. To summarize, there are many examples of OHL lines located in railroad corridors, however, these systems have the following disadvantages:

1. Pylons require greater right-of-way than UGC trenches.
2. Structures create a safety hazard for residents, passengers, and maintenance crews.
3. OHLs induce significant external magnetic fields, which raise concerns about possible electromagnetic coupling between the transmission system and other potential trackside utilities like pipelines and railroad facilities, as well as safety concerns for people [14].

More forward-thinking disadvantages, not found in prior art, are:

4. OHL offers less opportunity for capital cost-sharing with other utilities.
5. OHL will likely always require piecemeal construction methods, which can't take full advantage of the mobility offered by railroads.
6. The use of overhead space in railroad corridors may prevent potential future developments like electrification of the U.S. rail system, autonomous railcars, wireless power transfer, increasing weight limits and taller railcars, as well as Hyperloop or hybrid plane-train transportation system retrofitting.

On the other hand, the marked decrease in cost of UGC afforded by cross-linked polyethylene (XLPE) insulation, and the significant reduction of magnetic coupling between UGC and its environment, are strong motivators for investigating trackside UGC. Recently, the Direct Connect Development Company has been pursuing a project called SOO Green Renewable Rail that would place 349 miles of UGC, 85% of it being along a Canadian Pacific Railway route, to carry wind power from central Iowa to Chicago [16].

### 3. Cable Train: in-situ manufacturing of trackside UGC

To help further reduce the cost of UGC systems, we propose a mobile manufacturing platform, hereafter referred to as the “Cable Train,” for in-situ production of continuous lengths of cable, which exit the train and are directly laid into trenches that have been created alongside the tracks. Figure 2 (a) shows a plan view schematic of the Cable Train placing in-situ produced cable into a trackside trench as the train moves along.

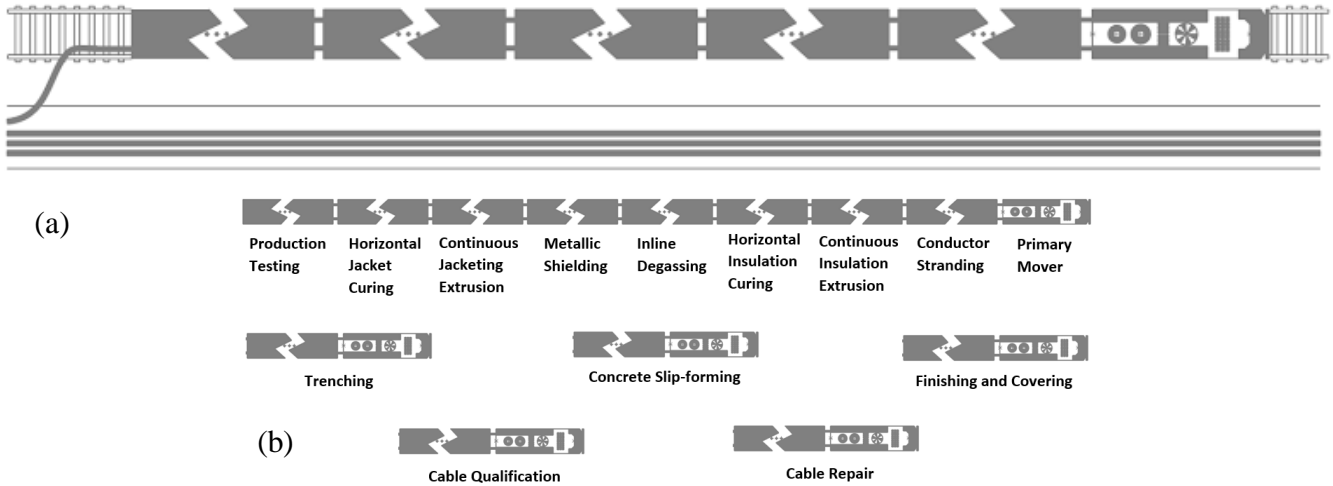

**Figure 2:** (a) Plan view of the “Cable Train,” which lays in-situ produced high voltage cable into an adjacent, open trench. The train comprises a number of modules necessary to manufacture high voltage cable – wire stranding, extrusion, curing, and degassing, among others. (b) A diagram showing the possible separation of Cable Train functional units. Each of these modules may be independently hauled in order to fully realize the maximum working speed of each module.

The Cable Train is a mobile manufacturing platform that is constructed from modified or dedicated rolling stock. The intent is for it to incorporate all the manufacturing abilities of a stationary, state-of-the-art cable manufacturing facility and produce continuous lengths of cable in the same way as it is manufactured for submarine cable systems. The Cable Train approach exploits the advantages of trackside UGC to the utmost extent:

1. In addition to railroads making transportation of machines, material, and personnel cheaper to begin with, the Cable Train replaces the transportation of cable with the transportation of raw materials, at a much higher packing fraction, and a much lower cost. Cable installation has been shown to be 30-40% of the entire lifetime cost of underground systems. Circumnavigating obstacles related to vehicle width, bridge height, weight restrictions, cable reel access, winch access, and steep terrain, by installing cable as it is made, will significantly reduce cost [17].
2. Furthermore, in-situ manufacturing cable in lengths much longer than those transportable by road haulage will mostly eliminate cable splices. Not only are cable splices costly to install, each splice pit taking several workers several weeks to install, cable accessories have been found to account for up to 37% of system failures, due to design, manufacturing defects, and poor workmanship [8].

The Cable Train may be complemented by other modules that perform trenching, concrete slip-forming, cover-and-finish, commissioning, and cable repair. The entire series of modules envisioned is shown in Figure 2 (b), which together can achieve all the advantages derived from trackside UGC discussed so far.

### *3.1 In-situ manufacturing challenges*

The functional requirements for the Cable Train should be driven by the necessity to produce cable that is low cost and high quality – all in a narrow space. The train must provide manufacturing capabilities equivalent to those of a state-of-the-art facility and there must be provisions to perform thorough qualification of each cable, the resources required to do so being housed all, or in part, within the Cable Train.

Underground cable is produced through a series of additive stranding, extrusion, armouring, and taping operations. Three manufacturing steps have been identified as presenting major challenges for the Cable Train. (1) **Insulation extrusion** requires screen-packs to filter impurities out of the extrusion melt. Replacing screen-packs requires interrupting production. During (2) **Curing** it is critical to maintain concentricity. To this end, most facilities use vertical continuous vulcanization (VCV) or catenary continuous vulcanization (CCV) lines which require significant height and horizontal distance not available on rolling stock. (3) **Degassing** is a critical step often accelerated by placing finished shipping lengths of cable inside large heated chambers. In order to maintain a continuous length of cable, the Cable Train must have provisions to degas cable inline.

### *3.2 Continuous Extrusion*

In order to allow longer extruder runs without the need to stop operation for replacing screen-packs, cleaning equipment, and reloading extrusion lots, redundant triple-extruders can be used with a dual crosshead to provide indefinitely long operation. One set of extruders would be exclusively operated while the screen-pack in the inactive extruder is replaced and the equipment cleaned. The previously inactive extruder and previously active extruder can be simultaneously ramped-up and ramped-down, respectively. Melt can be partially discarded through purge valves in both extruders until the change-of-duty has been completed [18]. Ideally, resin feed will be contained in a semi-closed system that ensures plastics remain clean during loading and regular operation [9]. This setup will allow for continuous insulation and jacket extrusion on the Cable Train.

### *3.3 Horizontal Curing*

To accomplish axisymmetric curing without a vertical tower or catenary pressure vessel, a process similar to the Mitsubishi-Dainichi Continuous Vulcanization (MDCV) process can be used. MDCV uses an extended extrusion die, which relies on residual extrusion pressure and heat to achieve concentric curing while the extrusion remains constrained within a segmented “long land die” (LLD). The process relies on the high viscosity of specifically chosen insulation materials, kept perfectly cylindrical by the extended extrusion die, to provide sufficient viscous resistance to conductor sagging. The conductor may be continuously rotated to ensure that it stays at the center of the die despite circumferential flow of insulation material. This machinery has been used to produce cable up to 550kV [18]. A schematic of the LLD from the original patent (1975) is shown in Figure 3 below.



A concept for a dedicated piece of rolling stock is presented here to heat the cable, after insulation extrusion, to accelerate degassing, by using a new, inline cable handling system to increase the amount of cable contained in a single railcar, thereby reducing the number of cars required to reach the desired degassing time without affecting the cable production speed. The design would utilize boxcars equipped with servo-actuated reels upon which the cable winds on, and then off, from one reel to another, thereby effectively increasing the path-length the cables take through each car, thereby increasing the amount of cable present in a car at any given time and decreasing the required number of cars to achieve the desired degassing time. Because the metallic shield, the component most sensitive and readily damaged by bending, is not added until after the insulation degassing, these cars can use reels of diameter less than that recommended for handling finished shipping lengths of cable (usually 20-35x the total outer diameter of the cable). Figure 4 shows a simplified view of the degassing car, showing the path of cable through the car and the approximate size and scale of the equipment.

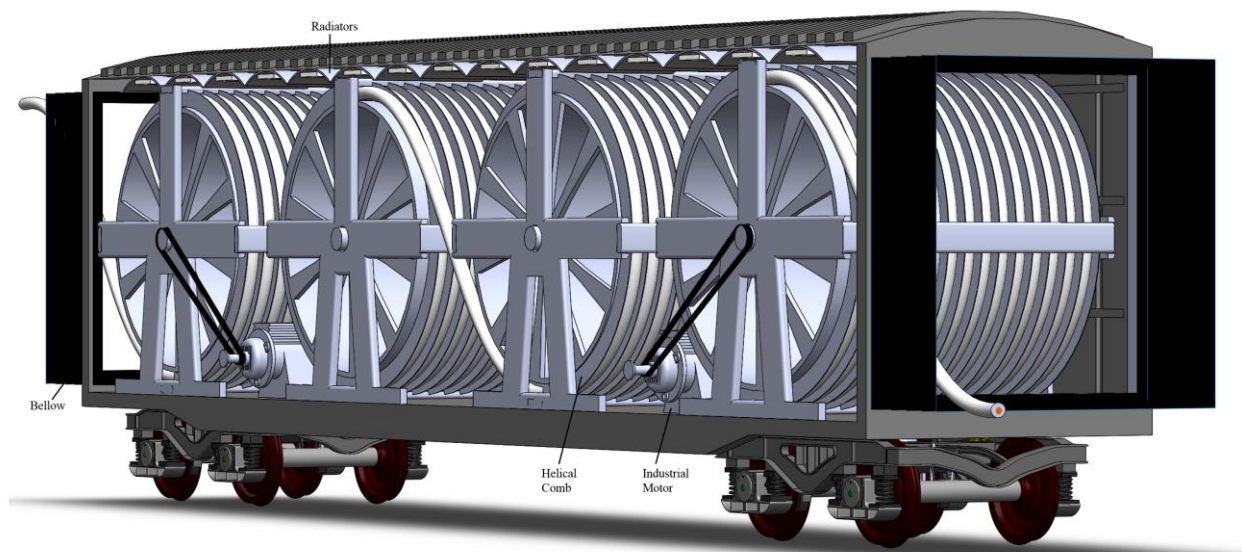

**Figure 4:** Illustration of an inline cable handling system concept that increases the length of cable that can safely fit into a single boxcar, thereby decreasing the number of cars that are needed to sufficiently degas cable after insulation extrusion. On each reel, the cable travels across the width of the railcar/container, alternating direction with each reel. Helical guides are used to guide the cable across each reel and overhead radiant heaters provide the heat necessary to expedite the degassing process.

The cable in this system must move axially across the length of one drum, as it rotates with the motion of the drum, before unbending and being passed to the neighboring drum, whereupon it travels axially in the opposite direction. Therefore, the cable moves side to side, perpendicular to the direction of travel of the train, as it moves down the length of the train by traveling from drum to drum. In order for cable to move axially down the length of each drum, it must slide axially, otherwise the cable would simply attempt to accumulate on each drum, leading to no progress along the length of the train, and likely leading to the cable breaking. To accomplish this axial sliding the cable must be “combed” to guide the cable along a spiral path as it rotates on each drum. Three concepts for such hardware are presented hereafter: (a) **a continuous helix**, (b) **discrete spiraling “fins,”** and (c) **discrete spiraling rollers**. A common misconception upon presentation of these designs is that the “combs” rotate synchronously with the drum and cable. In actuality, the combs must remain stationary relative to the railcar/container, providing a spiral path for the cable to be pulled through under the influence of friction between it and the rotating drum. Figure 5 shows schematics of the cable combs.

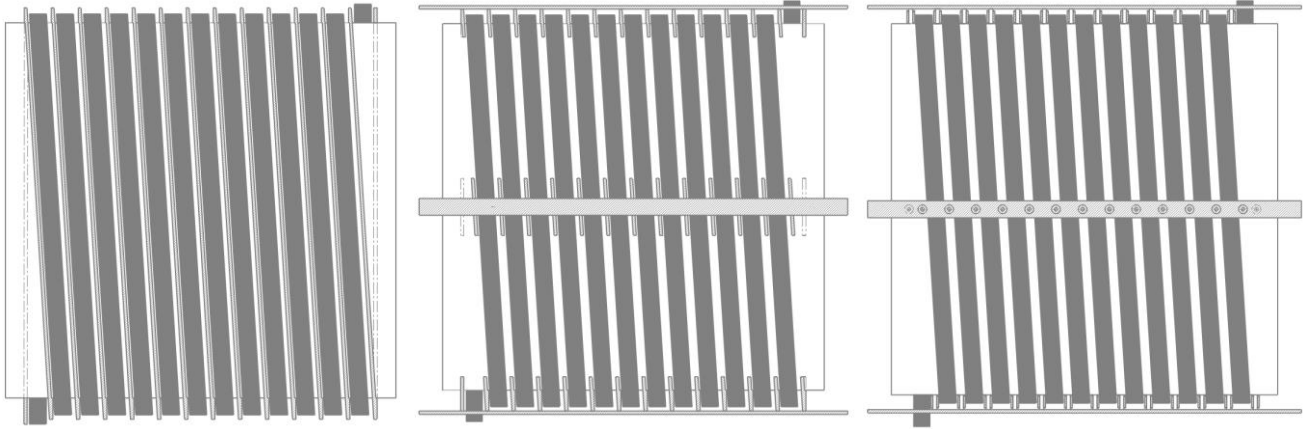

**Figure 5:** Schematics of a continuous helical comb (Left, a), discrete “fin” comb (Middle, b), and a discrete roller comb (Right, c) that ensure the cable moves axially down the length of the drums.

A first-order manifestation of a spiral guide is a **continuous helix** [Fig. 5 (a)], which makes constant contact with the cable to push it axially down the length of the drum. Breaking the continuous helix into **discrete fins** [Fig. 5 (b)] saves material cost while still enabling safe cable handling. Replacing the discrete “fins” with **discrete rollers** [Fig. 5 (c)] increases cost and complexity, but it reduces friction and hence the risk presented by sliding contact between the comb and cable insulation inherent in concepts (a) and (b).

Cable Data and Parameter Input		Copper Stress Calculations		XLPE Insulation Stress Calculations	
Drum/Cable Diameter Factor	22	Yield Strength (Pa)	3.33E+08	Yield Strength (Pa)	2.00E+08
Cable Insulation OD (m)	0.125	Shear Modulus (Pa)	4.60E+10	Shear Modulus (Pa)	4.83E+09
Conductor OD (m)	0.06	E (Pa)	1.10E+11	E (Pa)	1.30E+09
Diameter of Drums (m) for Degas	2.75	EI (Pa*m <sup>4</sup> )	0.437	EI (Pa*m <sup>4</sup> )	1.48E+04
Diameter of Neutral Axis of Cable (m)	2.88	Radius of Curvature (m)	1.41	Radius of Curvature (m)	1.44
Area of Conductor (m <sup>2</sup> )	2.83E-03	Curvature (/m)	0.710	Curvature (/m)	0.696
Packing Fraction Circles (Milliken)	0.9069	I (m <sup>4</sup> )	3.98E-12	I (m <sup>4</sup> )	1.13E-05
Single Conductor Strand Diameter (m)	0.003	Internal Moment (Pa*m <sup>3</sup> )	0.311	Internal Moment (Pa*m <sup>3</sup> )	1.03E+04
Number of Layers in Conductor	10	Max Bending Stress (Pa)	1.17E+08	Max Bending Stress (Pa)	5.65E+07
Total Number of Strands (Concentric Stranded)	331	Density (kg/m <sup>3</sup> )	7.76E+03	Density (kg/m <sup>3</sup> )	1.27E+03
Lay Angle (Degrees)	45	Max weight of suspended cable (N)	2.91E+03	Max weight of suspended cable (N)	2.91E+03
Max Tensile Traction Force on Cable (N)	1.70E+05	Loading	84%	Loading	16%
Clearance Between Cable on Neighboring Drums (m)	0.1	Tensile Stress from dead weight (Pa)	8.65E+05	Tensile Stress from dead weight (Pa)	4.93E+04
Distance Between Drum Centers (m)	3.1	Total Max Axial Stress (Pa)	1.18E+08	Total Max Axial Stress (Pa)	5.66E+07
Clearance to Bottom of the railcar (m)	0	Normal Force Drum to Cable (N/m)	3.49E+03	Normal Force Drum to Cable (N/m)	3.49E+03
Max Length of Suspended Cable (m)	8.74	Delta Deformation of Insulation (m)	1.64E-06	Delta Deformation of Insulation (m)	2.48E-05
Weight Per Meter of Cable (N/m)	333	Strain	5.05E-05	Strain	7.63E-04
Poisson's Ratio Copper	0.364	Contact Patch Area (m <sup>2</sup> ) per unit length	6.28E-04	Contact Patch Area (m <sup>2</sup> ) per unit length	3.52E-03
		Force Constraint	3.49E+03	Force Constraint	3.49E+03
<b>Calculation of Optimum # of Reels per Railcar</b>	<b>CSX Boxcar</b>	Side Wall Pressure from Drum (Pa)	5.56E+06	Side Wall Pressure from Drum (Pa)	9.91E+05
Inner Height (m)	3.327	Coefficient of Friction XLPE to Steel	0.2	Coefficient of Friction XLPE to Steel	0.2
Inner Width (m)	2.896	Normal Force from Comb (N/m)	698	Normal Force from Comb (N/m)	698
Inner Length (m)	15.418	Delta Deformation of Insulation (m)	5.34E-07	Delta Deformation of Insulation (m)	8.49E-06
Drum Diameter (m)	2.75	Strain	1.78E-05	Strain	2.61E-04
Clearance Between Cable on Neighboring Drums (m)	0.1	Contact Patch Area (m <sup>2</sup> ) unit length	3.58E-04	Contact Patch Area (m <sup>2</sup> ) unit length	2.06E-03
Drums Per Car/Container Vertical (#)	1	Force Constraint	700	Force Constraint	700
Drums Per Car/Container Horizontal (#)	4	Side Wall Pressure from Comb (Pa)	1.95E+06	Side Wall Pressure from Comb (Pa)	3.39E+05
Total Drums Per Car/Container (#)	4	Torque on Cable @ Cable Center (N*m)	34.9	Torque on Cable @ Cable Center (N*m)	34.9
Clearance Between Drum and Walls (m)	0.4	Internal Torque Constraint (N*m)	34.89	Internal Torque Constraint (N*m)	34.89
Cable Length per Car/Container (m)	625.7	Max dPhi / dx (Degrees/m ) from Rolling	1.41E-05	dPhi / dx (Degrees/m ) from Rolling	1.41E-05
Degassing Time (hrs)	168	Max Stress from Twist (Pa)	1.95E+04	Max Stress from Twist (Pa)	4.26E+03
Cable Production Speed Goal (m/hour)	80				
Number of Cars/Containers (#)	22	Max Axial Stress Total (Pa)	1.18E+08	Max Axial Stress Total (Pa)	5.66E+07
Length of Degassing Section of the Train (m)	339.2	Max Radial Stress Total (Pa)	5.56E+06	Max Radial Stress Total (Pa)	9.91E+05
		Max Circumferential Stress Total (Pa)	1.95E+04	Max Circumferential Stress Total (Pa)	4.26E+03
		Safety Factor	2	Safety Factor	2
		Von Mises at Danger Point (Pa)	1.63E+08	Von Mises at Danger Point (Pa)	7.93E+07
		Good for Static Case?	YES	Good for Static Case?	YES
		Von Mises at Comb/Cable Contact (Pa)	1.66E+08	Von Mises at Comb/Cable Contact (Pa)	7.98E+07
		Good for Static Case?	YES	Good for Static Case?	YES
<b>Continuous Comb</b>		<b>Discrete Comb</b>		<b>Discrete Rollers</b>	
Thickness (m)	0.0127	Thickness (m)	0.0127	Radius of the Rollers (m)	0.0141
Largest Expected Cable OD (Gap) (m)	0.125	Largest Expected Cable OD (m)	0.125	Approximate Largest Expected Cable OD (m)	0.125
Length of Drum (m)	2.286	Angle (Degrees)	0.874	Length of Drums Flange-to-Flange (m)	2.286
Revolutions	16.51	Number of Comb Rows	4	Number of Roller Rows	4
Angle (Degrees)	0.874	Circumferential Sep. (m)	2.16	Number of Revolutions	14
Normal Force on Comb (N/m)	698	Length of Flat Section (m)	0.05	Angle (degrees)	0.971
Delta Deformation of Insulation (m)	4.28E-07	Normal Force on Comb (N/m)	3.15E+04	Force Acting on Each Roller (N)	1.58E+03
Strain	1.37E-05	Delta Deformation of Insulation (m)	7.94E-04	Delta Deformation @ Contact (m)	4.62E-04
Contact Patch Area (m <sup>2</sup> ) per unit length	4.63E-04	Strain	0.0244	Strain	0.0142
Force Constraint	698	Contact Patch Area (m <sup>2</sup> ) unit length	9.93E-04	Elliptical Contact Patch Area (m)	8.52E-05
Side Wall Pressure from Drum (Pa)	1.51E+06	Force Constraint	3.15E+04	Force Constraint (N)	1.58E+03
FEA Result?	Good!	Side Wall Pressure from Comb (Pa)	3.17E+07	Pressure on Insulation (Pa)	1.85E+07
		Fin Attachment Good? (FEA)	YES	Roller Attachment Good? (FEA)	Good!
		Von Mises at Fin-Cable Cont. (Pa)	6.95E+07	Von Mises at Roller-Cable Cont. (Pa)	7.07E+07
		Safety Factor	2.88	Safety Factor	2.83
		Flat Section of Fin Sufficiently Long?	YES	Roller Radius Sufficiently Large?	YES
		<b>Worst Case Precaution - Fin Terminal Radius</b>		Pitch (m)	0.153
		Radius at the End of Fin (m)	5.00E-03	Shift Between Bars (m)	0.0383
		Force from Friction in Jamming (N)	698	Drum Length (m)	2.286
		Delta Deformation of Insulation (m)	4.01E-04	Drum Length Constraint	2.286
		Strain	0.0123		
		Contact Patch Area (m <sup>2</sup> ) unit length	4.35E-05		
		Force Constraint	698		
		Side Wall Pressure from Comb End (Pa)	1.60E+07		
		Von Mises at Fin-Cable Cont. (Pa)	7.14E+07		
		Safety Factor	2.80		
		Terminal Radius of Fin Sufficiently Large?	YES		

**Figure 6:** The table above shows example numbers from a design spreadsheet made to aid in the design of the helical cable combs proposed in the discussion of a “space-saving inline handling system for roll-to-roll processing” above. The spreadsheet calculates all Von Mises stresses and re-checks the stresses assuming different types of cable combs. All inputs are shown in black and outputs are shown in blue. Highlighted green cells represent force constraints where stresses and deformations are solved for. This tool is made available for study and further evolution [Supplementary Material I].

Figure 6 shows a spreadsheet design tool that has been developed to maximize the length of cable able to fit inside containers and railcars of varying sizes as well as calculate the stresses at various danger points in the cable throughout the cable handling system due to bending, tension, torsion, and side-wall pressure. This tool is made available for further development [Supplementary Material 1]. The kinematic feasibility of this cable handling topology has been proven with a scale model, which is shown in Figure 7.

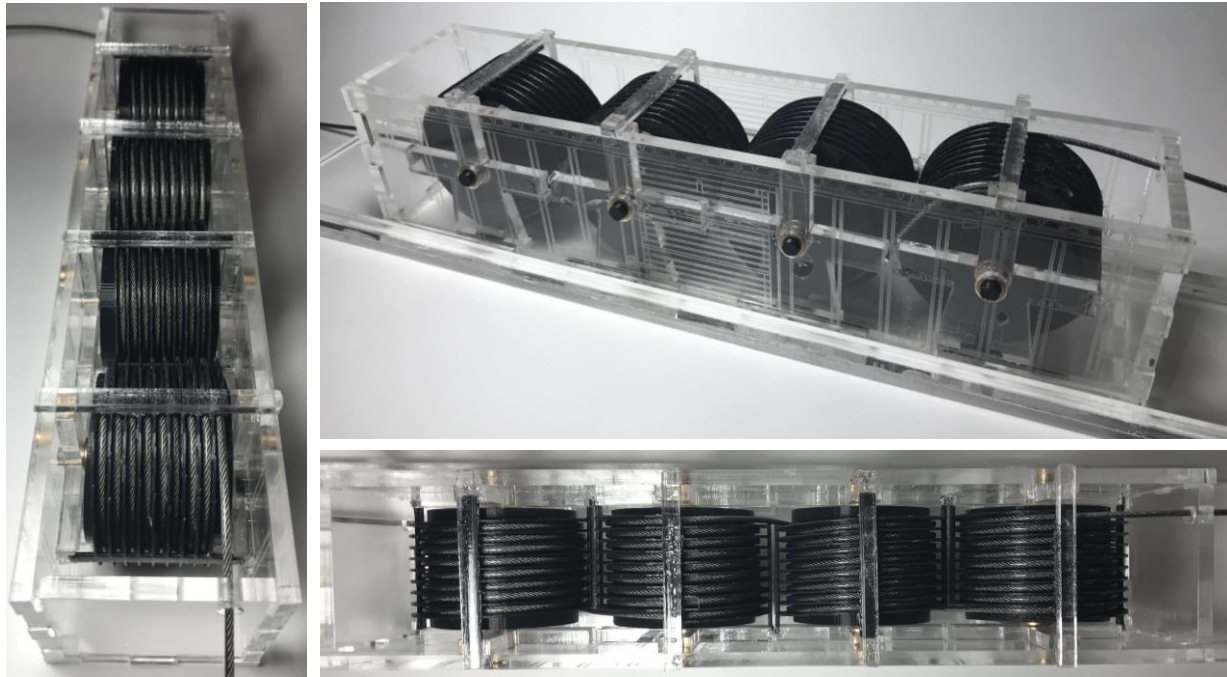

**Figure 7:** A 50:1 scale model of a concept for a “degassing train” capable of greatly increasing the amount of cable in a series of railcars while continuously processing it as the train moves relative to it in an inertial reference frame. The cable proceeds down the length of the train by passing from reel to reel, moving axially across the length of each reel under the influence of non-rotating helical guides. According to an analytical model, the bending, tension, side-wall pressure, and accumulated twist in the cable are safe. This accomplishes approximately a 40x decrease in the length of the degassing section of the train.

Ideally, the servo-controlled reels will be able to control the amount of slack between reels such that there is never excessive axial load on cable cores. While the cables pass through this series of degassing cars, a plenum with heating elements and circulation fans or radiant heaters and reflectors mounted on the top of the boxcars will provide the heating power necessary to accelerate degassing. Radiant heating may provide the most efficient heating method by concentrating the power density at a wavelength for which the absorption by the cable insulation is maximized. This essentially mimics the process of placing cables in large kilns, typically performed at state-of-the-art manufacturing facilities. All of these details are illustrated in Figure 4.

### *3.5 Summary of manufacturing onboard the Cable Train*

Continuous extrusion, horizontal curing, and inline degassing, as they are discussed above, are viable measures for enabling continuous, in-situ cable manufacturing onboard a moving train. While it is not discussed in detail here, conductor stranding, armouring, and taping operations are crucial steps in the cable manufacturing process that must also be packaged for operation on rail cars. It appears feasible for a combination of tubular and planetary stranding machines to be placed onboard the Cable Train in order to

achieve a wide range of conductor sizes, but it will require nontraditional solutions for automated bobbin changing, which in a factory is accomplished with automated dollies or hydraulic, floor-mounted jacks.

Taping and armouring setups, whether they use a wrapping machine or a metallic shield extruder, have much smaller footprints. While foil-wrapping currently requires periodic interruption to replace bobbins, the Hansson-Robertson continuous lead extruders can extrude a molten lead shield over 50km long [9].

The continuous production of extremely long lengths of cable, even longer than lengths produced for submarine applications, requires redundant machinery. For example, a wire stranding machine cannot be reused to produce the successive layers of the conductor. One stranding machine must be dedicated to the production of each layer. Likewise, separate LLDs used to cure insulation and jacketing, respectively, require independent heating and cooling facilities. Because of the need for redundant stranding and curing machines, this contributes significantly to the Cable Train capital cost estimates discussed in Section 4.

Several expected advances in cable technology could make cable manufacturing a simpler process, and better suited for continuous, in-situ production. Advances in insulating polymers and conductor design may reduce the thickness required to provide sufficient dielectric strength and reduce conductor size required to achieve desired ampacity, respectively. The resulting decrease in cable sizes will decrease bending limits and increase the amount of cable that can fit into railcars.

Finally, the potential use of thermoplastic insulation [20], may allow for the elimination of the curing and degassing processes altogether, significantly decreasing the cost and complexity of manufacturing continuous lengths of cable onboard a moving train.

### *3.6 Meeting manufacturers' standards*

For a developer and/or grid operator to purchase underground cable for use in their systems, cables must meet quality standards set by the relevant regulatory body. There are currently no international standards that exist for ultra-high voltage (UHV) underground systems. Hence, for the purpose of setting functional requirements for the manufacturing performance of the Cable Train, we elect to use the current standards for extra-high voltage (EHV) HVDC cables.

Standards stipulate that production tests must be performed, during and after production, on material lots and cable samples, to ensure cable integrity in many dimensions [21], [22], [23]. Qualification tests are required before a cable is installation-ready and qualified for use at the rated voltage and power. Much of this work requires personnel to perform inspections, operate the testing equipment, and make decisions regarding resampling, retesting, repairing, and discarding of finished cable. Dedicated rolling stock outfitted with the necessary testing equipment (Tensile Testing Machine, Forced Air Convection Oven, Boiling Pool, Transformer, 5kAV Generator, and Weathering Machinery) and personnel to perform production tests, or a plan to transport samples to satellite facilities, would be necessary [21], [22].

For short, land cables, testing frequency requirements call for a periodic halt in production and severing of the cable [21], [22]. The Cable Train may implement on-line optical measurement, radiation imaging, ultrasonic transducers, or other continuous sensors, to be developed, to replace invasive tests and allow production of long lengths without severing. However, it is still logistically difficult to perform high voltage tests and partial discharge tests on long lengths of cable.

Naturally, long submarine cables face these same challenges and specific standards for long submarine cables offer more flexibility [23]. For long cables, the standards allow for the high voltage test to be performed with a lower voltage at a longer duration. The standards also allow for the partial discharge test to be performed on samples rather than on finished cable lengths [23].

In general, standards have been adapted to accommodate cable design and, in the end, everything is agreed on between the buyer and cable supplier. The exact testing requirements for extremely long lengths of cable (> 100km) will be defined and remaining obstacles can be addressed at that time.

#### 4. Lifetime cost and total build cost for trackside UGC created by the Cable Train

While, in the past, transmission cost may have been a modest percentage of the total cost of electric power, connecting to remote renewables will present situations where transmission cost could make up a significant portion of generation cost, and the uncertainties integral to transmission costing become even more important [24].

Here, a first order model for Cable Train project costing, that is reconciled with prior art, is used to study a generic trackside system, and investigate potential cost-related benefits of trackside systems and the Cable Train, itself.

In railway corridors, construction costs and land values are relatively decoupled from surrounding regions because the railway corridors have their own isolated characteristics. Therefore, despite the lack of specification in this study, building on railroads is a relatively repeatable process, assuming tracks are well-maintained, so this study should still produce results representative of a trackside system.

Methods and data used in the subsequent cost analysis come from several sources, both published studies and private communication with members of industry. Influential publications include a study performed by Parsons Brinckerhoff, in 2012, which gathered transmission project cost data from equipment suppliers and equipment owners [17]. This data is reconciled with RSMMeans construction costing data and high voltage cable kilometric cost data [17], [25]. Another publication we draw on heavily is Benato and Napolitano “Overall Cost Comparison Between Cable and Overhead Lines Including the Costs for Repair After Random Failures,” *Electra* No. 265 (2012), which provides an analytical review of UGC lifetime cost [26]. Overhead cost estimates for the Cable Train itself are derived from private communication with machinery suppliers and, where all inventions related to the current study are concerned, our own analysis and best judgement is used. The result is an analysis with several top-down assumptions and, where appropriate, detailed bottom-up calculations.

The lifetime cost of a transmission system (LCTS) is defined as:

$$LCTS = I + E + T + D + OM + R + SE \quad [\$]$$

Where,

$I$  ≡ Initial Capital Costs: planning, Cable Train, cable, route construction, converter stations

$E$  ≡ Energy Loss Costs: energy lost and additional power generation needed to replace these losses

$T$  ≡ Territorial Costs: cost of land use according to land value accounting data

$D$  ≡ Decommissioning Costs: decommissioning, dismantling, disposal, recycling, and environmental rehab

$OM$  ≡ Operation and Maintenance Costs: costs of monitoring and preventative maintenance

$R$  ≡ Random Repair Costs: repair and/or replacement of parts that fail because of unpredictable causes

$SE$  ≡ Social and Environmental Costs: the monetized cost of health effects and environmental impact

Social and environmental costs (SE) are not addressed here because they are difficult to quantify without a specific project in mind. The individual cost categories that were expected to be affected by the Cable Train and/or trackside UGC, received particular attention in this analysis. Cost advantages derived from both the Cable Train and trackside UGC are discussed, briefly, here.

#### *4.1 Cable Train economic advantages*

The cost of transporting cable reels in traditional projects, which contributes to initial capital cost through cable installation, is replaced by the lesser cost of transporting raw materials to the Cable Train for in-situ cable manufacturing. (I)

One of the major benefits of the Cable Train is the elimination of cable joints and associated splice pits. Joints account for a large percentage of historical cable failure rates, and joint repair is extremely costly. We have adopted a 37.1% reduction in cable failure rate, resulting from the elimination of joints [8]. (I, OM, R)

#### *4.2 Trackside UGC economic advantages*

Construction cost often varies due to land costs, accessibility, environmental regulations, and meeting local codes and regulations, but using railroads as transmission corridors decouples system cost from location because of the accessibility of the entire railway system.

All personnel, materials, and machines can be transported by rail throughout the life of the trackside UGC system. This accessibility to the entire railway system will make surveying the corridor easier and unexpected modifications to cable routing should be avoided. While traditional UGC construction poses many natural barriers that may make it difficult to use the same type of installation throughout the entirety of the route, railroads present relatively few obstacles, which comprise: culvert crossings, train stations, overhead bridge foundations, road access for track maintenance, railroad merging points, tunnels, property lines, cattle guards, road crossings, as well as poles and substations for electrified railways. Special constructions like cable bridges and directional drillings, which have been found to increase construction cost by 5.6% of the build cost, could be largely avoided as a result [17]. (I)

Railroad transmission projects will require significantly cheaper site accommodations, during construction, as railroad access points will already have accommodations. (I) Preparatory work, such as root and rock removal, demolition, de-vegetation, culverts, access roads, retaining walls, etc., which must be done prior to the commencement of the principle construction, will be less costly [17]. (I)

Whereas some past transmission line projects have called for up to 3000 workers during peak construction [27], it is thought that the use of rolling stock machinery to perform continuous processes will significantly reduce the time and labor required to complete trackside transmission projects. (I, OM, D, R)

The most common cause of damage to traditional UGC systems is third-party damage from other service providers and construction crews. Trackside UGC will benefit from relatively few third parties, without knowledge of the UGC's presence, performing work near it. (R)

Civil work can increase the cost of repairing and replacing damaged underground components by up to 50% [26]. Trackside UGC will have reduced civil repair costs because parts and equipment are cheaper to move. (R) Some randomly damaged parts may be repairable (e.g. a damaged cable section could be removed and splice pits added), whereas others can only be replaced. This depends on the severity of damage and on the relative costs of repairing and replacing. Decreasing the cost of civil work could increase the probability that failed components will be repairable, further reducing overall cost (R). Trackside UGC will make route patrols that monitor soil conditions, surrounding water levels, cable splices, terminals, cross-bonding, and ROW markings, less costly as well. (OM)

#### 4.3 System example and economic model

The transmission system, which will be the focus of the following cost analysis, is a trackside, point-to-point, 4 GW-rated, 660kV, 3000A, bipolar system, comprising two 200mm OD cables and voltage source controlled (VSC), 2GW, 12-pulse converters at each pole. The analysis assumes a 40-year life, and 5% discount rate. The width of the trench that runs alongside the tracks and contains the cable is 2m, although the distance of the trench away from the tracks will require an additional 3-5m of space so as to not disturb the subgrade beneath the rails too much. The calculations assume no sharp changes in direction, relatively flat terrain, and no major topological obstacles.

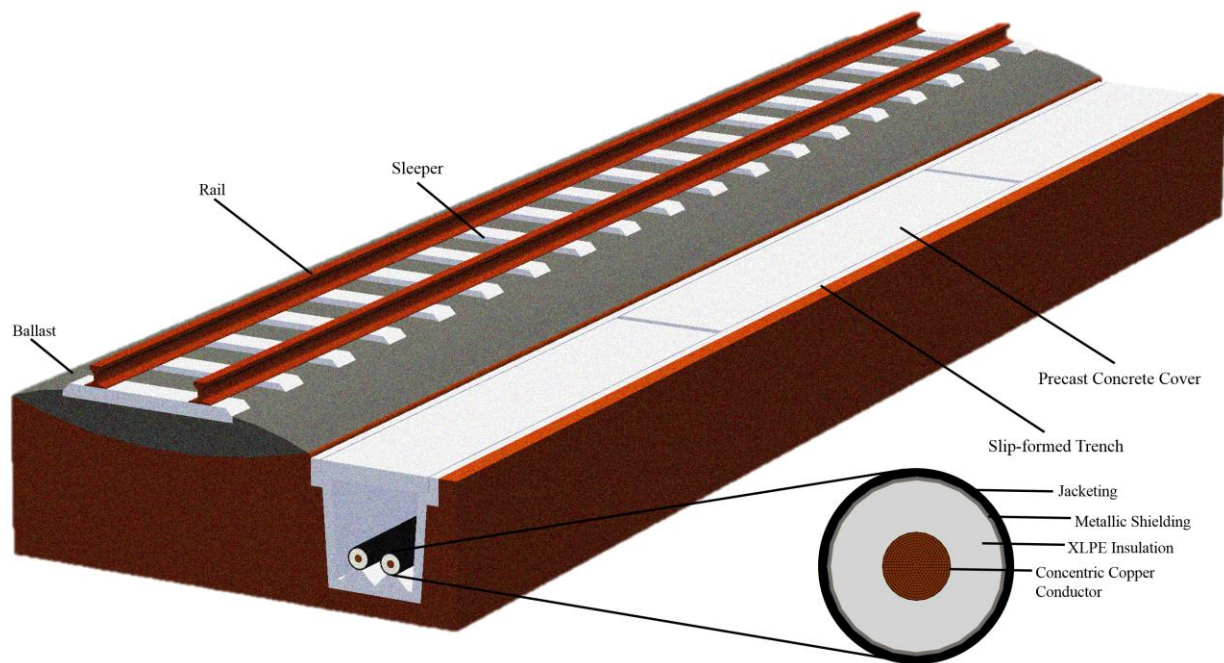

**Figure 8:** An example of a UGC system located next to railroad tracks. The bipole cable configuration is housed inside of a slip-formed concrete duct bank and covered with precast concrete slabs. Heat transfer analysis and simulation concluded that compacted backfill, which could comprise native soil, would be necessary to prevent overheating of the cable cores.

Components of the trackside UGC system are illustrated in Figure 8. The cables are surrounded by a slip-formed concrete duct structure and a precast concrete cover. The reasons for this decision are twofold: the concrete duct structure prevents compromise of the railroad foundation, and, the risk of future train derailment may require isolation of the system for the purpose of protecting both the cable and the derailed cargo. The alternative is to directly bury the cable in the ground next to the railroad using shoring or concrete only where necessary. If nothing else, the inclusion of the continuous slip-formed duct bank is an added contingency that makes the analysis more conservative.

Thermal analysis and simulation concluded that the duct structure must be filled with compacted native soil to promote heat transfer away from the cables. Open-air trenches are not feasible. This is in good agreement with industry practice where sometimes even the thermal conductivity of native soils, when dry, can limit ampacity and specially engineered thermal backfills must be used. Provisions must also be made for distributed temperature sensing (DTS) along the route.

While the cable system is the sole output of the Cable Train, which excludes termination systems, including the cost of terminations and converter stations is necessary to conduct a meaningful comparison with current project costs, and so they have been included in part of the subsequent analysis.

#### 4.4 Cable Train: production system capital costs

Capital cost estimates, shown in Table 1, for the components of the Cable Train, might seem high, but these costs become amortized over long transmission distances and many projects: The lifetime of the Cable Train is taken to be 10 years, or, about 20 completed projects.

Table 1. The constituent costs of machinery in the Cable Train. All numbers are the averages of at least two quotes solicited from major suppliers in each industry. Numbers in parentheses are installation costs associated with that item (the labor, equipment, and materials that are required to get the machine(s) into a working condition onboard a train).

Capital Components Grouped by Function	Approximate Cost (USD)
Wire Payoff, Planetary Strander, Closing Die/Bench, Taper, Caterpillar/Capstan, Dancer, (Installation)	\$2,000,000 to \$2,500,000 (+\$600,000)
MDCV Line w/ Triple-Extrusion and LLD Curing, (Installation)	\$15,000,000 to \$17,000,000 (+\$5,000,000)
Degassing w/ 80 Cars, 4 Drums per Car, Capable of 28 Day Degas at 80 m/hr Production Rate, (Installation)	\$10,000,000 to \$12,000,000 (+\$3,000,000)
Armouring Payoff, Armouring Machine, Caterpillar/Capstan, Dancer, (Installation)	\$500,000 to \$700,000 (+\$150,000)
MDCV Line w/ Single-Extrusion and LLD Curing, (Installation)	\$6,000,000 to \$8,000,000 (+\$3,000,000)
Caterpillar, Dancer, Buffer, (Installation)	\$300,000 to \$400,000 (+\$100,000)
QA: Tensile Testing, Weathering, Boiling Pool, Convection Oven, Generators, Transformer, (Installation)	\$500,000 to \$600,000 (+\$100,000)
Primary Mover 6,000hp ×2	\$6,000,000 to \$8,000,000
<b>Total Cost for Major Machinery, Rolling Stock, and Assembly</b>	<b>\$52,250,000 to \$61,150,000</b>

#### 4.5 Lifetime cost and total build cost results

Figures 9 & 10 show the detailed itemization of fixed and variable costs, as well as assumptions made, which amount to I, OM, E, D, T, R, total build cost, and LCTS. This spreadsheet is available for others to study and evolve [Supplementary Material 2]. Figure 11 shows the estimated lifetime cost of a trackside HVDC UGC system produced by the Cable Train, broken down into gross cost categories discussed above. Capital costs (I), account for a large fraction of the lifetime cost so it is further divided into its constituent costs: Cable Train capital cost, converter station cost, cable cost, construction cost, and planning cost. Figure 12 shows the estimated build cost of a Trackside HVDC UGC system produced by the Cable Train graphed alongside the self-reported, projected build costs of other HVDC projects of similar capacity (all OHL except for Northern Pass, which was also never constructed due to regulatory delays) in today's dollars [27], [33]-[39].

<b>HVDC Trackside UGC Characteristics</b>	
Transmission line route length, $L$ (km)	350
Transmission line voltage rating, $V$ (kV)	660
Transmission line power capacity, $P$ (GW)	4
Trench width, $w$ (m)	2.0
Trench depth, $d$ (m)	1.5
Concrete slipform and precast thickness, $t$ (m)	0.1
Cable outer diameter, $OD$ (m)	0.2
Number of cable splices, $N$	-
System Lifetime, $lifetime$ (years)	40
Discount Rate, $rr$	5%
<b>HVDC Trackside UGC Produced by Cable Train - Capital Costs, (I)</b>	
Capital cost of the full Cable Train, $CT\_Capex$ (\$)	61,150,000
Lifetime of the Cable Train in number of projects completed, $CT\_lifetime\_projects$	20
Preparatory work cost, $cost\_prep\_work$ (\$)	-
Termination and converter station cost, $cost\_converter$ (\$) [17], [28]	700,000,000
Contingency added to historical submarine cable manufacturing cost [17]	10%
Cable raw material and production cost for bipole, $kilocost\_cable$ (\$/km) [17]	2,970,000
Total cable cost for entire route, $cost\_cable$ (\$)	1,039,500,000
Equipment cost, $cost\_equipment$ (\$)	1,739,500,000
Cable Train raw material inventory in equivalent cable distance, $CT\_inventory$ (km)	12
Total raw material shipping distance during project, $mat\_transport\_dist$ (km)	4,900
External, unpriced cost to ship cable raw materials by rail, $cost\_railroad\_ship$ (\$/ton-km) [29]	0.005
Cable weight per meter, $cable\_weight$ (kg/m)	50
Total cost of cable raw material delivery during project build, $cost\_mat\_shipping$ (\$)	16,172
Number of skilled workers required for cable installation, $workers\_req$	20
Cable Train rate of cable production, $CT\_rate$ (m/hr)	180
Labor cost for skilled workers performing cable installation, $hourly\_wage$ (\$/hr)	40
Cable installation cost, $kilocost\_installation$ (\$/km)	1,555,556
Trenching cost, $kilocost\_trenching$ (\$/km) [25]	23,000
Slip-forming cost for duct-structure, $kilocost\_slipform$ (\$/km) [25]	74,000
Precast cover cost, $kilocost\_precast$ (\$/km) [25]	187,000
Fuel costs for all machines, $kilocost\_fuel$ (\$/km)	30,000
Construction contingency as a percentage of base construction cost, $build\_contingency$ [17]	15%
Construction cost, $kilocost\_construction$ (\$/km)	2,150,035.09
Total Construction Cost, $construction\_cost\_total$ (\$)	752,512,283
Total Build Cost, $total\_build\_cost$ (\$)	2,495,069,782.73
Planning and engineering cost as a percentage of total construction cost, $percent\_planning$ [17]	20%
Planning and engineering cost, $cost\_planning$ (\$)	499,013,957
I (\$)	2,994,083,739

**Figure 9:** Itemized capital costs of an HVDC trackside UGC system produced by the Cable Train. All lifetime costs are reported in net present value (NPV). This spreadsheet is made available for further study and improvement [Supplementary Material 2].

<b>Lifetime Operation and Maintenance Costs of Trackside UGC (OM)</b>	
Annual cost of preventative maintenance as a percentage of system equipment cost, <i>percent_imp</i> [26]	0.1%
Lifetime preventative maintenance, <i>Imp</i> (\$)	29,848,231
OM (\$)	29,848,231
<b>Lifetime Energy Loss Costs of Trackside UGC (E)</b>	
Circuit loading factor (CLF) of transmission system, <i>clf</i> [26], [30]	35%
Short run marginal cost (SRMC) of generation, <i>srmc</i> (\$/MWh) [17]	45
Resistive energy losses over lifetime of trackside UGC system, <i>kilocost_resistance</i> (\$/km)	41,831
Converter energy losses as a percentage of power [17]	2%
Converter energy losses over lifetime of trackside UGC system, <i>cost_convert_losses</i> (\$)	183,983,842
Total lifetime energy losses of trackside UGC system, <i>total_energy_losses</i> (\$)	198,624,811.03
Long run marginal cost (LRMC) of generation, <i>lrmc</i> (\$/MWh) [17]	50
Loss load factor (LLF), <i>llf</i> [17]	39%
Peak power losses (PPL), cost of power required to replace losses, <i>ppl</i> (MWh)	271,057
Lifetime power losses, <i>cost_power_losses</i> (\$)	232,554,515
E (\$)	431,179,326
<b>Decommissioning and End-of-Life Costs of Trackside UGC (D)</b>	
Decommissioning costs as a percentage of total build cost, <i>percent_decommissioning</i> [26]	5%
D (\$)	17,720,694
<b>Territorial Cost of Trackside UGC (T)</b>	
Trench width, <i>w</i> (m)	2.0
Land cost for "noncore, non-metro, non-micro, land without a town of 2,500," <i>cost_land</i> (\$/acre) [31]	1,655
Kilometric territorial cost, <i>kilocost_territory</i> (\$/km)	817.92
T (\$)	286,271
<b>Lifetime Cost of Random Repairs for Trackside UGC, (R)</b>	
Historical failure rate, <i>hfr</i> (/100 km-year) [32]	0.3
Percent of historical failures attributable to joints, <i>failures_joints</i> [8]	37.1%
New failure rate for Trackside UGC system without joints, <i>nfr</i> (/100 km-year)	0.19
Cable repair cost, <i>cost_random_repair</i> (\$/event)	2,970,000
R (\$)	33,658,174.19
<b>Total Lifetime Cost of Trackside UGC System Produced by the Cable Train (LCTS)</b>	
	3,506,776,436

**Figure 10:** Itemized lifetime costs of an HVDC trackside UGC system produced by the Cable Train. All lifetime costs are reported in net present value (NPV). This spreadsheet is made available for further study and improvement [Supplementary Material 2].

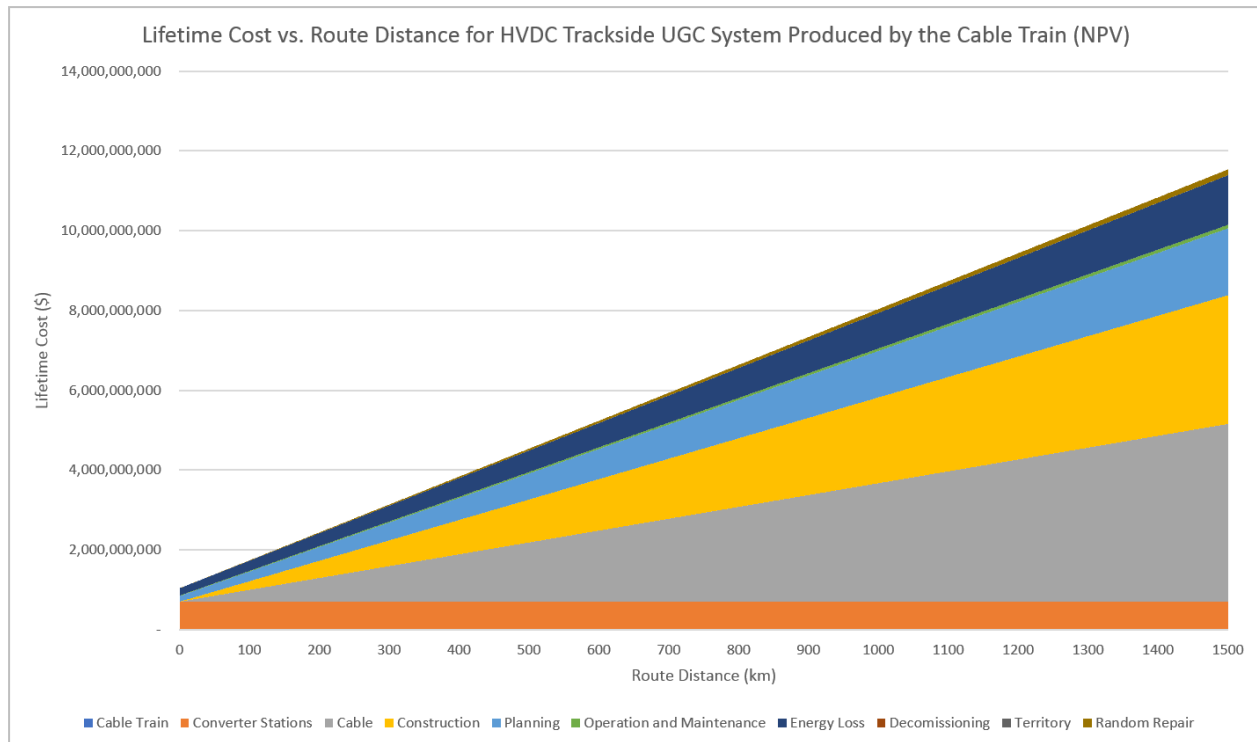

**Figure 11:** The estimated lifetime cost of a trackage HVDC UGC system produced using the Cable Train, broken down into gross cost categories. Cost of the Cable Train itself is small compared to other capital costs.

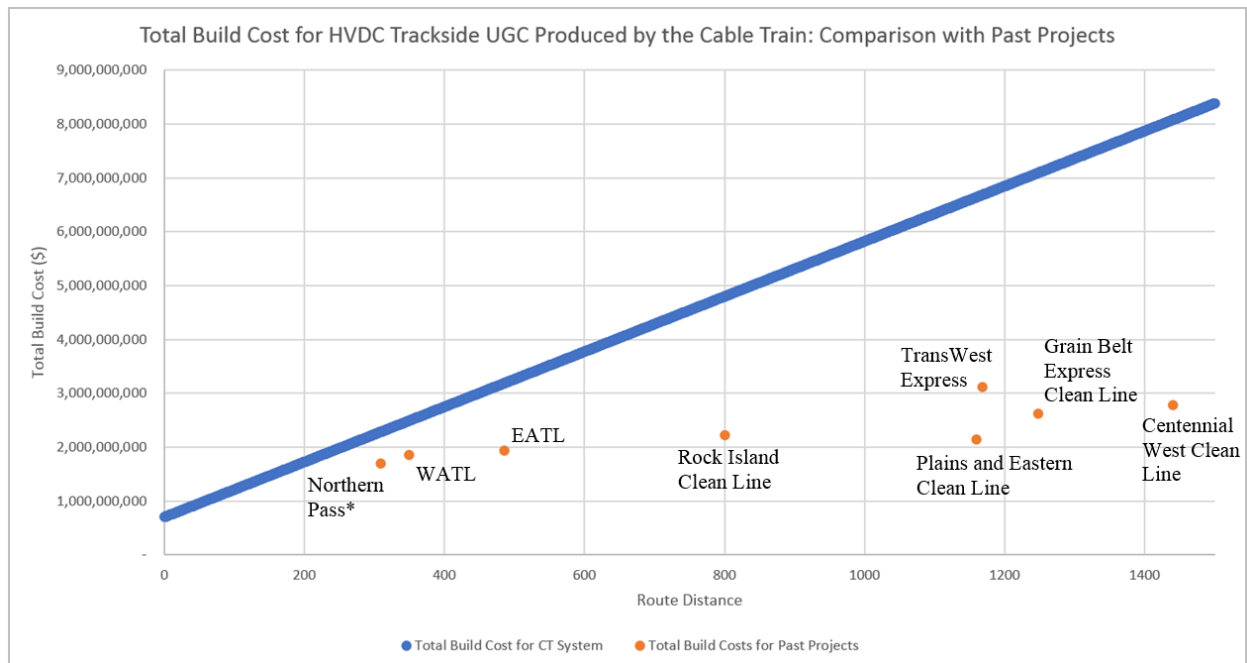

**Figure 12:** The estimated build cost of a trackage HVDC UGC system produced by the Cable Train, graphed alongside the self-reported, projected build costs of other HVDC projects [27], [33]-[39]. \*Northern Pass is no longer being pursued due to regulatory delays.

#### *4.6 Analysis of costs: economic benefits of the Cable Train and trackside UGC*

The result that the build costs of systems produced by the Cable Train are on the same order-of-magnitude as self-reported costs from past projects is encouraging. The result that the cost of the Cable Train, itself, is a very small percentage of the total build cost, and lifetime cost, is also worth noting.

This analysis shows that the total-build-cost-ratio between trackside UGC produced by the Cable Train and past HVDC projects (UGC/OHL), is approximately 1.34 to 3.09. Given that historical UGC/OHL cost ratios range from 4 to 14 [7], these results are very encouraging.

Trackside UGC and the Cable Train, together, potentially produce many other economic advantages, some of which are too difficult to quantify and were not considered in the analysis above. Because railroads in the U.S. are privately owned by a finite number of companies and individuals, and because underground cable is essentially invisible, trackside UGC projects should benefit from relatively less regulatory delays, and the costs that are incurred as a result. This economic advantage should not be underestimated.

Adding the decreased likelihood of regulatory delays to the decreased UGC/OHL cost ratio shown above may mean that trackside UGC produced by the Cable Train could be competitive, if not cost-competitive, with OHL in dedicated corridors.

It has been difficult to find component-level data or estimates on specific cost categories (e.g. historical costs solely attributable to reel transportation or wages for particular types of laborers) which makes it difficult to clearly highlight individual economic benefits or reconcile cost differences overall.

Many of the advantages discussed in 4.1 and 4.2 are not completely captured by the cost analysis presented, which makes conservative assumptions wherever possible, and avoids overreliance on subjective contingency and discount multipliers. Benefits that were hard to quantify, and did not enter this analysis, are:

1. Cost savings gained from avoiding regulatory delays.
2. Planning cost savings from the uniformity and accessibility of railroads.
3. Reduction in labor required for cable installation.

Costs which should be identical for Cable Train systems and past projects (like cable raw material costs) could be significantly different, and account for the positive cost differences shown in Figure 12. It is also possible that, for cost categories in which trackside UGC produced by the Cable Train should be cheaper, other project estimates have adopted such low numbers to begin with, that even our informed discounts were not sizable enough to manifest an advantage. This is the problem with comparing results with projects from different times, places, and institutions. Future developers, regulatory and reliability commissions, utilities, and operators must perform their own case-based estimates of total build cost, lifetime cost, and cost of ownership, to compare specific transmission options.

### **5. Future Work**

The Cable Train concept appears to be viable from an economic standpoint, although more detailed modelling is needed so detailed cost analysis can identify the optimal funding and ownership models for the Cable Train and trackside UGC. In addition, from a technological perspective, the primary challenge of degassing looks to be solvable using serial combed cable reels and thus warrants full-scale development and testing.

Work should thus focus on the development of all the Cable Train cars in a holistic manner, compact and modularized near-rail trenching, and concrete duct slip-forming. Additionally, strategies for cable qualification, cable repair, and finishing capabilities that can be integrated into rolling stock must be developed.

It is also possible that new materials will eliminate vulcanization and degassing, greatly decreasing the cost of high voltage cable, and new backfills will enable narrower duct banks and smaller conductors for the same capacity [17], and thus should be diligently pursued.

## 6. Conclusions

This work is the result of a detailed study [40] that showed utilizing railroads as corridors for power transmission may provide an economically attractive means of connecting remote renewable power generating stations to demand centers in the grids of the future. The increased mobility of machines, materials, and personnel on railroads could make the practice of installing and maintaining such systems less costly compared to traditional methods required by dedicated transmission line corridors. The use of private railways may avoid conflicts with external stakeholders and eliminate the regulatory delays that have plagued many renewable energy transmission projects. Railroad companies and landowners could thus also expand their business model to include transport of electrons in addition to transport of cargo.

The concept of a Cable Train that is capable of in-situ manufacturing continuous lengths of HVDC cable, could further reduce cost by replacing cable reel transportation cost with the cost of transporting raw material and by eliminating costly and vulnerable cable splices. The technical feasibility of this approach, discussed above, included continuous extrusion, horizontal curing, and concepts developed for an inline degassing system. Cost analysis has shown, preliminarily, that trackside UGC, and the Cable Train, provide economic benefits which may significantly reduce the cost gap between UGC and OHL.

Trackside UGC systems, produced using the Cable Train, should be considered in future plans to build cross-boundary, long-distance HVDC transmission grids to allow penetration of remote, landlocked, renewable energy. Moving forward might best be achieved by a pre-competitive technology consortium with member companies and public entities capable of completing and fully realizing the proof-of-concept designs proposed. All aboard the Cable Train!

## BIBLIOGRAPHY

- [1] California Energy Commission, “Clean Energy & Pollution Reduction Act SB 350 Overview” <http://www.energy.ca.gov/sb350/> (accessed 11/02/2017)
- [2] Veazey Shelby, “Energy Efficiency: How Boston and New York are Ahead of the Game,” Phoenix Energy (October 27, 2017) <http://www.phoenixenergygroup.com/blog/energy-efficiency-how-boston-and-new-york-are-ahead-of-the-game> (accessed 11/02/2017).
- [3] AWS Truepower, “United States – Land-Based and Offshore Annual Average Wind Speed at 100m,” National Renewable Energy Laboratory (September 19, 2012) [https://www.nrel.gov/gis/images/100m\\_wind/awstwsdpd100onoff3-1.jpg](https://www.nrel.gov/gis/images/100m_wind/awstwsdpd100onoff3-1.jpg) (accessed 01/01/18).
- [4] Roberts, Billy J., “Concentrating Solar Resource of the United States,” National Renewable Energy Laboratory (September 19, 2013) [https://www.nrel.gov/gis/images/eere\\_csp/national\\_concentrating\\_solar\\_2012-01.jpg](https://www.nrel.gov/gis/images/eere_csp/national_concentrating_solar_2012-01.jpg) (accessed 01/01/18).
- [5] S. Gao and M. Barnes, et al. “Making VSC-HVDC control robust to geomagnetically induced

current,” 2016 IEEE Power and Energy Society General Meeting (PESGM), Boston, MA, 2016, pp. 1-5.  
doi: 10.1109/PESGM.2016.7741253

<http://ieeexplore.ieee.org/stamp/stamp.jsp?tp=&arnumber=7741253&isnumber=7741056>  
(accessed 08/05/2017).

[6] Alexander E. MacDonald, et al., “Future cost-competitive electricity systems and their impact on US CO<sub>2</sub> Emissions,” Nature Climate Change (January 2016)

<https://www.nature.com/articles/nclimate2921.pdf> (accessed 05/01/2018).

[7] Alonso, F. and Greenwell, C. “Underground vs. Overhead: Power Line Installation-Cost Comparison and Mitigation”. PowerGrid International, Electric Light and Power,

[https://www.elp.com/articles/powergrid\\_international/print/volume-18/issue-2/features/underground-vs-overhead-power-line-installation-cost-comparison-.html](https://www.elp.com/articles/powergrid_international/print/volume-18/issue-2/features/underground-vs-overhead-power-line-installation-cost-comparison-.html) (accessed 04/15/2018).

[8] Hampton, Nigel, “Medium Voltage Cable System Issues,” Georgia Tech Research Corporation, National Electric Energy Testing, Research, and Applications Center (NEETRAC): February 2016

[9] Worzyk, Thomas, “Submarine Power Cables: Design, Installation, Repair, Environmental Aspects,” Springer Dordrecht Heidelberg (London: 2009) <https://link.springer.com/book/10.1007%2F978-3-642-01270-9> (accessed 11/30/2017).

[10] Union Pacific Railroad, “Fiber Optic Focus,” Information Technologies Department, Volume 31, Issue 1.

[11] Henkels & McCoy, “Henkels & McCoy – Railroad Mounted Cable Plow,” YouTube (April 10, 2012).

[12] The United Illuminating Company, “Petition to the Connecticut Siting Council for Declaratory Ruling of No Substantial Adverse Environmental Effect for the Stratford 115-kv Transmission Line Upgrades Project” Stratford, Fairfield County, Connecticut (June 2, 2017).

[13] “Principles and Practices for Inductive Coordination of Electric Supply and Railroad Communications/Signal Systems.” Association of American Railroads and Edison Electric Institute, September, 1977.

[14] M. Frazier, P. Thomas, H. Robertson, J. Dunlap, and T. Morgan, “Transmission Line, Railroad and Pipeline Common Corridor Study,” IEEE Transactions on Power Delivery, Vol. PWRD-1, No. 3, July 1986.

[15] “IEEE Guide for Analysis and Definition of DC Side Harmonic Performance of HVDC Transmission Systems,” IEEE Power and Engineering Society, IEEE Std. 1124 (2003).

[16] SOO Green Renewable Rail <http://www.soogreenrr.com/>

[17] Parsons Brinckerhoff and Cable Consulting International Ltd. (CCI), “Electricity Transmission Costing Study: An Independent Report Endorsed by the Institution of Engineering & Technology,” (Parsons Brinckerhoff: January 2012) <https://www.theiet.org/factfiles/transmission-report.cfm> (accessed 06/01/2018).

[18] Discussions with industry experts.

[19] Fuwa, et al., "Method for Forming and Vulcanizing Vulcanizable Materials," United States Patent 3928525 (Dec. 23, 1975).

[20] G. Stevens and B. Philpot, et al., "Whole-life costs and environmental assessment of high voltage power cable systems," *Electra* 266 (2013).

[21] International Electrotechnical Commission (IEC), "Power Cables with Extruded Insulation and Their Accessories for Rated Voltages and Above 150kV ( $U_m = 170kV$ ) up to 500kV ( $U_m = 550kV$ ) – Test Methods and Requirements," IEC: 62067 Edition 2.0, 2011-11.

[22] Insulated Cable Engineers Association, Inc. "Standard for Extruded Insulation Power Cables Rated Above 46 Through 345Kv" ANSI/ICEA S-108-720-2012, November 27, 2012.

[23] CIGRE Working Group B1.27, "Recommendations for Testing of Long AC Submarine Cables with Extruded Insulation for System Voltage above 30 (36) to 500 (550) kV," *Electra* No. 490, February 2012.

[24] Andrade, Juan, Baldick, Ross, "Estimation of Transmission Costs for New Generation," White Paper UTEI/2016-09-2, 2017, <https://energy.utexas.edu/policy/fce/publications> (accessed 07/01/2017).

[25] Babbit, Christopher, et al. "Site Work & Landscape Costs with RSMeans Data" The Gordian Group Inc. 2016.

[26] Benato, Roberto, Napolitano, Domenico, "Overall Cost Comparison Between Cable and Overhead Lines Including the Costs for Repair After Random Failures," *Electra* No. 265, December 2012.

[27] Northern Pass Transmission Project <http://www.northernpass.us/project-overview.htm>

[28] "Impacts of HVDC Lines on the Economics of HVDC Projects," CIGRE Technical Brochure 388, Joint Working Group B2/B4/C1.17, August 2009 <https://e-cigre.org/publication/388-impacts-of-hvdc-lines-on-the-economics-of-hvdc-projects> (accessed 05/01/2018).

[29] David Austin, "Pricing Freight Transport to Account for External Costs," Congressional Budget Office (Washington DC), Working Paper March 2015 [https://www.cbo.gov/topics/results?topic=All&field\\_display\\_pubtype\\_value\\_many\\_to\\_one=working+paper&congressional\\_session=All&budget\\_function=All](https://www.cbo.gov/topics/results?topic=All&field_display_pubtype_value_many_to_one=working+paper&congressional_session=All&budget_function=All) (accessed 10/15/2017).

[30] R. Benato, A. Paolucci, "EHV AC Grounding Electrical Power, Performance and Planning," Springer, ISBN: 978-1-84882-866-7, 2010.

[31] Larson, William, "New Estimates of Value of Land of the United States" Bureau of Economic Analysis, April 3, 2015.

[32] Update of service experience of HV underground and submarine cable systems", Publication TB 379, Working group B1.10, CIGRÉ, Paris, 2009.

[33] Western Alberta Transmission Line (WATL) <http://www.altalink.ca/projects/view/168/western-alberta-transmission-line-watl>

[34] Eastern Alberta Transmission Line (EATL) <http://www.parklandgeo.com/atco-electric-eastern-alberta-transmission-line-eatl>

[35] Grain Belt Express Clean Line <https://www.grainbeltexpresscleanline.com/site/home>

[36] Centennial West Clean Line <https://www.centennialwestcleanline.com/site/home>

[37] TransWest Express <http://www.transwestexpress.net/>

[38] Plains and Eastern Clean Line <https://www.plainsandeasterncleanline.com/site/home>

[39] Rock Island Clean Line <https://www.rockislandcleanline.com/site/page/project-description>

[40] L. Gray, “Cable Train: A Platform for In-Situ Manufacturing of Underground Cable” submitted to the Massachusetts Institute of Technology, Department of Mechanical Engineering, June 2018.

[Supplementary Material 1] Degassing\_Car\_Design\_Spreadsheet.xlsx

[Supplementary Material 2] LCTS\_CT\_HVDC\_Trackside\_UGC.xlsx