



21, rue d'Artois, F-75008 PARIS  
<http://www.cigre.org>

**CIGRE US National Committee**  
**2012 Grid of the Future Symposium**

## **HVDC Technologies for the Future Onshore and Offshore Grid**

**E.M. Callavik\*, P. Lundberg\*, M.P Bahrman\*\*, and R.P. Rosenqvist\*\*,  
ABB  
Sweden\* & USA\*\***

### **SUMMARY**

This paper describes voltage source converter (VSC) and line commutated converter (LCC) technologies and cable technologies for HVDC for point-to-point links and multiterminal applications. Today VSC links above one gigawatt are feasible for VSC and projects up to eight gigawatt for LCC are in construction.

A rapid development of VSC has taken place with respect to power rating and loss reduction since the first 50 MW onshore VSC has been installed in 1997. VSC was taken offshore on oil and gas platforms for power from shore in 2005. Now offshore wind farm connections up to 900 MW with losses lower than 1% per converter are under construction. VSC-HVDC with overhead lines are also in operation.

Extruded DC cable technologies have developed so that they can accommodate power levels in gigawatt range at voltage levels of 320 kV. This is a key enabler for offshore wind integration and for undergrounding transmission system on land.

### **KEYWORDS**

AC-DC power converters, Cables, HVDC transmission, Offshore installations, Wind farms

## INTRODUCTION

The first commercial High Voltage Direct Current (HVDC) was installed to power the Island of Gotland from shore by a 96 km 100 kV subsea cable in 1954. Since this first 20 MW transmission system more than 100 HVDC systems have been installed world wide. Some of the major technical breakthroughs have been the introduction of thyristor-based valves in the 70's, the first large multiterminal schemes in the early 90's, IGBT-based converters in the latter 90's and UHVDC transmission system operation at 800 kV with transmission capacities above 6 GW.

The first commercial voltage source converter (VSC) HVDC was introduced 1997 on the island of Gotland. Since then ratings and applications has progressed rapidly. The power and voltage for Gotland Light™ was 50 MW and  $\pm 80$  kV. Fifteen years later power and voltage ratings have increased by a factor of twenty and six times, respectively, e.g. the 2 x 1000 MW INELFE project between France and Spain and the  $\pm 500$  kV Skagerrak 4 project between Norway and Denmark. Since 2005 HVDC voltage source converters has been deployed to power offshore oil and gas platforms from shore and since 2010 also to transmit power from offshore wind generators to shore [1].

VSC-HVDC has already been applied or are in delivery in applications that are onshore, offshore, back-to-back, and multi-terminal enabled as well as in topologies that are symmetric, asymmetric, 2-level, 3-level and multilevel. Furthermore transmission systems with underground and sea extruded cables; mass-impregnated cables as well as overhead lines are in operation. The converter development has allowed converter losses to be reduced to below 1% per converter.

The development of extruded DC cable technologies has been intense since the end of 1990's. This has enabled cable based HVDC applications to expand in voltage and power levels and created a range of VSC based HVDC applications supporting the grid expansions to handle the changing mix of generation and increased demand of security in the power systems. Already about 5 GW of transmission of offshore wind located in the North Sea has been awarded up to 2015. As offshore generation increases it makes sense to design a grid for better utilization of the transmission systems.

The key technological cornerstones needed to plan and start building the first parts of such HVDC grids are available today. These offshore grids can be progressively introduced using HVDC point-to-point connections based on the latest voltage source converters. Several CIGRE working groups are working on guidelines on the required technical solutions, e.g. B4-52, B4-57, B4-58, B4/B5-59 and B4-60 as well as the Cenelec TC8X Study group on Technical Guidelines for HVDC Grids. Also regulatory aspects and harmonization of grid codes are needed on national and international levels. Several CIGRE working groups are working on these issues (B4-52 and B4-56).

## VSC BASED HVDC TRANSMISSION AND CABLE TECHNOLOGIES

HVDC based on the VSC technology has been used since 1997 with start of the first project Gotland HVDC Light with rating of 50 MW and  $\pm 80$  kV. The losses were around 3 % per converter station and the development focused on reducing losses and increasing voltage and power ratings. The result of these efforts can be seen in Fig. 1. The reduction down to 1 % losses per converter station was possible through work in three areas. First, the evolution of the IGBTs has reduced switching and conduction losses via more optimized components as well as increased voltage/current level per device (4.5 kV/2000A instead of 2.5 kV/1200A). Secondly the converter topology changed from two-level to the cascaded two level converter (CTL) technology that has reduced full-load losses to ca. 1 % per converter and reduced the need for AC filters [6]. Thirdly the switching schemes have been optimized giving lowest possible losses in steady state while enabling fast response at fault cases. The well-known differences in topologies and switching patterns are described in the literature [2].

The cable technologies have advanced through research as mentioned in the introduction. The first commercial projects were as mentioned above  $\pm 80$  kV for land cable systems. The key in this

development is to master the extrusion technologies when it comes to DC properties such as conductivity in the insulation but also to handle accessories such as joints and terminations to form a complete cable system.. Both underground links [1] and submarine connections [3] are installed. Today, the total length of extruded HVDC cables is already in similar order as of classical mass impregnated HVDC cables. At present the extruded HVDC cables are produced and offered at 300 - 320 kV and power ratings up to about 1 GW [4].

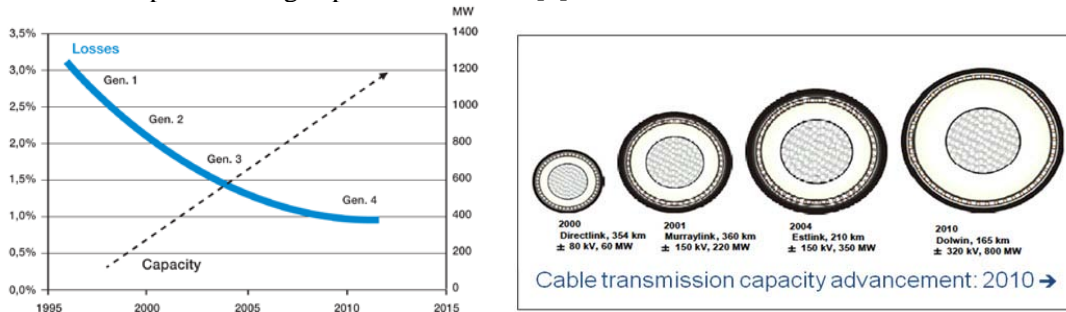

Fig. 1 (left) and Fig. 2 (right). Evolution of converter station losses and power handling capacity for a HVDC Light® station from 1997 until today. Extruded DC cable development since 2000 with project references included showing voltage and power ratings.

## HVDC-BASED OFFSHORE POWER-FROM -SHORE

The cable technology that has supported the offshore applications since 2005 when the first two compressors at the Troll A oil and gas platform in the North Sea were powered from hydro resources by a 70 km subsea link from the Norwegian shore [3]. The installation has been followed by a similar design for the Valhall platform in 2011 and two additional links to Troll A awarded recently. The Valhall transmission system includes onshore and offshore converter stations which operate as electrical drives together with the cable wound, high-voltage motor on the platform to feed the entire Valhall field [4]. The main reasons for powering from shore are to reduce costs, improve operation efficiency and to minimize emission of green house gases. Since IGBT-based VSC-HVDC (HVDC Light™) is self-commutated, the converters require no existing AC voltage to operate.

## HVDC-BASED OFFSHORE POWER-TO-SHORE

Borwin 1 in the North Sea outside Germany is the first VSC-HVDC for power-to-shore from an offshore wind farm put into operation in 2010 to enable transmission of 400 MW, i.e. 80 wind generators of 5 MW [5]. The offshore converter is located 130 km from the coast. The generators feed into a 36 kV AC cable system which is transformed to 154 kV for the HVDC Light™ offshore station. The receiving station connected to the German 380 kV grid 75 km from the coast.

Dolwin 1 and 2 are examples of North Sea wind projects to be commissioned during 2013 and 2015, respectively. These VSC systems will operate at  $\pm 320$  kVDC, transmitting 800 and 900 MW of peak power, respectively. The Dolwin transmission systems use the cascaded two level converter (CTL) technology. These multilevel converters has reduced losses to ca- 1 % per converter and reduced the need for AC filters [6]. A simplified single line diagram of Dolwin 1 is outlined in Fig 3. For references, more presentations of HVDC links provided by ABB are available on internet [7].

## HVDC GRIDS

A high penetration of variable and remote wind energy creates a demand for a stronger power grid for transmission to load centers and efficient power balancing. A HVDC Grid enables rapid power flow control including change of flow direction in the time range of seconds over long distance with relatively low power losses. Furthermore, HVDC enables a distributed interconnection to major load

centers located far from the optimum power generation and between major cities and industrial sites with non-simultaneous peak and low loads as ways of creating a secure and power-balanced system.

Classic line-commutated converter (LCC) HVDC multi-terminal schemes have been available for more than two decades, e.g. the 2000 MW New England-Hydro Quebec MTDC commissioned in 1992. Recently a  $\pm 800$  kV four converter MTDC was announced to be in operation in 2014-2015 in India to connect North East India with Agra rated at a maximum power of 8000 MW including 2000 MW overated capacity [7].

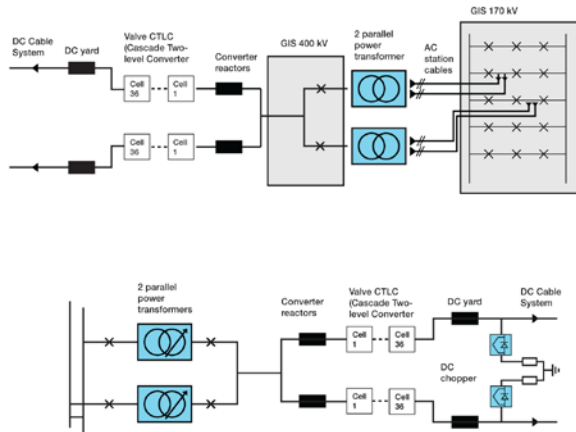

Fig. 3. Dolwin 1 simplified single line diagram. Offshore station depicted in the top with gas insulated switchgear (GIS) on the converter platform and GIS at the collector platform. Onshore station depicted in the bottom with DC choppers to handle DC faults.

VSC can change power by changing current direction, whereas LCC networks must do a voltage polarity switch by using DC switchyards. LCC HVDC needs to AC grids with a certain level of short circuit capacity and available reactive power compensation. These restrictions make the LCC unsuitable for larger HVDC grids. The developments in VSC technology i.e. increased power capacity and loss reduction [6], means that VSC is the preferred choice to build large HVDC networks [1].

### Regional HVDC Grids

A regional multi-terminal HVDC Grid has one HVDC zone meaning that it is not possible to separate the faulty part of the DC network at DC earth faults. Instead all circuit breakers on the AC side of the converters are opened; thereafter DC switches are used to isolate the faulty part if needed. Finally the system is re-energized. These types of networks can be built today. The limitations of such a grid is not in geographic size, as a matter of fact it could cover very long distance. The limitation of a regional grid is on the maximum in-feed power that can be lost in the connected AC network at the connection point, or the sum of several terminals connected in the same AC network.

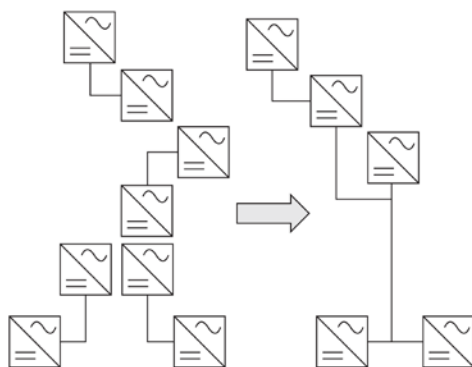

Fig. 4. Benefits with HVDC Grids compared to point-to-point connections.

The first regional VSC-based networks are also being planned for offshore and onshore applications in Europe and USA. Even more important recent point-to-point connections have been required to be grid-enabled to enable future expansion by connections to other DC systems. Regional MTDC has several benefits, e.g. the number of converters is reduced by one in a three node grid compared to building two point-to-point connections, i.e. a reduction with 25%. To replace four equal point-to-point connections in a radial manner only requires a five-node radial grid, i.e. the number of converters can be reduced from eight to five, cf. Fig. 4. Secondly, a reduction of the number of AC-DC conversion steps will reduce the converter losses, here 3%-units.

**Inter-regional HVDC Grids**

An inter-regional grid implies that the operational requirements specify that only parts of the HVDC network should be rapidly disconnected during a DC earth fault. Rapid fault isolation requires a DC circuit breaker and post-fault readjustment of the power flow. The required components are in a development stage that makes planning a possible reality today [10].

The HVDC grid could be built using overhead lines, plastic-insulated cables, mass-impregnated cables or combinations of these three solutions. All technologies have been selected in projects with VSC-HVDC for point-to-point up to 320 kVDC for plastic cables and 500 kVDC for mass-impregnated cables.

**OFFSHORE HVDC CONVERTER PLATFORMS**

With trends going towards huge offshore power plants located remotely on sites far out in a harsh and unforgiving environment, the suppliers can also expect an increased demand for platforms which has the capacity not only to give shelter to large AC-substations or HVDC converter station but also to act as hubs for operation and maintenance personnel. A innovative, robust and scalable platform has been designed addressing issues such as e.g. efficient production and easy installation requiring only a minimum of offshore works without the need of a heavy lift vessel or jack-up operations. It is a design which is flexible in respect to installation programs as it is possible to put in place all around the year.

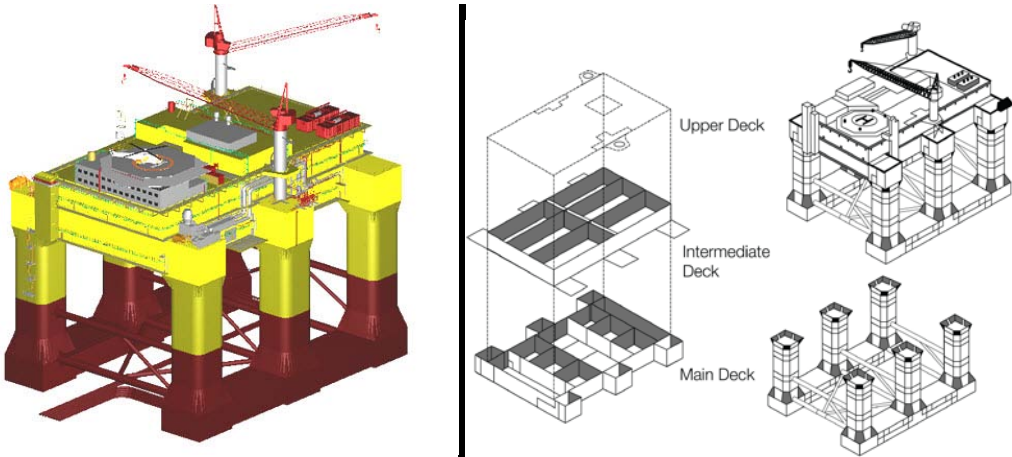

Fig. 5 (left) and Fig. 6 (right). 3-D model of HVDC hub for the Dolwin 2 project. Modularization of a gravity based structure platform. The topside structure is the same for all concepts, whereas the substructure is sized for water depth and power rating

The platform is a self-installing steel gravity base structure (GBS) intended to be floated to site and installed by ballasting, cf. Fig. 5. The modular approach is shown in Fig. 6. All equipment on the platform is installed and commissioned as far as reasonable at the yard. The offshore commissioning is limited to energization and trial run-after installation of the HV-cable. The transportation to the site is done by tug boats. Upon arrival to the site, the platform will be ballasted down to achieve skirt penetration. For permanent ballasting solid ballast will be filled into the lower part of all six columns.

## OFFSHORE HVDC GRID STUDIES IN EUROPE

Several parallel projects are underway in Europe to study the potentials and challenges with offshore grids. In a recent paper [10], the “Offshore grid” study compared DC grid hubs with versus individual connections, tee-in connections, and hub-to-hub connectors. To connect the future planned 129 GW of wind in the North and Baltic Seas an investment of €2B is estimated if only point-to-point connections are used. With a HVDC Grid approach 15% of investment could be saved. The financial analysis clearly pointed towards the benefit of an offshore grid.

## OFFSHORE HVDC GRID APPLICATIONS IN EUROPE

Over 50% of the US population lives in the coastal zones where the population density, especially in the mid-Atlantic and Northeast regions, is highest. Transmission distances from the Great Plains to coastal load centers can approach 2000 km and must pass through congested areas. These factors make development of offshore wind resources, e.g. in the mid-Atlantic and Northeast US attractive. Consequently several offshore wind projects have been proposed for this region. The Atlantic Wind Connection [12] consists of an offshore backbone HVDC transmission system, with capacity to connect up to 7000 MW of wind capacity, with multiple delivery points on the mainland grid.

Much of the development of transmission technology for integration of offshore wind can also be applied for accessing remote isolated wind resources located on land. The State of Hawaii for example plans to significantly increase its penetration of renewable resources on Oahu. Options include bringing in hundreds of MW of wind generation from the neighbouring islands of Molokai and Lanai which have only about 10 MW of local peak load.

## CONCLUSIONS

HVDC and Cable technologies exist today that enables offshore integration and planning of point-to-point DC links to be expanded into HVDC Grids. Several VSC-HVDC links are now in operation in offshore application in the harsh North Sea. Following the rapid increase in power transmission capacity and loss-reduction, several new projects up to the gigawatt range is in the construction phase.

## BIBLIOGRAPHY

- E. Koldby, M. Hyttinen, Challenges on the Road to an Offshore HVDC Grid, Nordic Wind Power Conference 2009, Bornholm Denmark 2009
- F. Dijkhuizen, S. Norrga, Large Scale Wind Integration of HVDC, EVER 2011, Monaco, 2011
- P. Jones, L. Stenius, The Challenges of Offshore Power System Construction Troll A, Electrical Power Delivered Successfully to an Oil and Gas Platform in the North Sea, EWEC, 2006
- B. Westman, S Gilje, M Hyttinen, Valhall Re-development Project, Power from Shore, PCIP Europe, 2010
- J. Kreusel, The future is now, ABB Review, pp 40-44, 4/2008
- B. Jacobson, P. Karlsson, G. Asplund, L. Harnfors, T. Jonsson, VSC-HVDC Transmission with Cascaded Two-Level Converters, B4-110, CIGRE 2010  
<http://www.abb.com/hvdc>, search e.g. North East – Agra or Dolwin 1
- M. Callavik, C. Yuen, J. Åhström, HVDC Supergrids for Continental Wide Power Balancing, 10th International Workshop on Large Scale Integration of Wind Power, October 2011
- C. M. Franck, HVDC Circuit Breakers: A Review Identifying Future Research Needs, IEEE TRANSACTIONS ON POWER DELIVERY, VOL. 26, NO. 2, APRIL 2011
- J. Häfner, B. Jacobson, Proactive Hybrid HVDC Breakers - A key innovation for reliable HVDC grids, B4 0264, CIGRE Bologna 2011
- P. Kreutzkamp, J. De Decker, N. Picot, OffshoreGrid: Techno-Economic Model for Future Offshore Electricity Transmission, 10 Int. Workshop on Large Scale Integration of Wind, 2011  
<http://atlanticwindconnection.com>