



21, rue d'Artois, F-75008 PARIS  
http : //www.cigre.org

**CIGRÉ US National Committee  
Grid of the Future Symposium  
Kansas City, October 28-30, 2012**

## **Grid Issues and Challenges Addressed by High Temperature Superconductor (HTS) Technology**

**J.A. Diaz de Leon II<sup>1</sup>, N. Reddy<sup>2</sup>, J. McCall<sup>3</sup>  
AMSC (American Superconductor Corp.)<sup>1,2,3</sup>(USA)**

### **SUMMARY**

High temperature superconductor (HTS) based electrical power equipment is now available from a number of manufacturers. Though the equipment, primarily cables and fault current limiters (FCLs), has so far seen only limited deployment, it can address many very difficult issues facing today's power grids. Some of the solutions are straight-forward while others will require further education and a shift in thinking within the utility industry. Understanding the technology and its applications is important for utility personnel in planning projects.

This paper discusses the basics and key operational characteristics of HTS-based FCLs and cables and presents an application example using them to demonstrate their novel use in the power system. In this example, paralleling two or more substations by interconnection of their low side buses is shown to be a simple and cost effective means to increase load-serving capability of existing substations while maintaining or improving system reliability.

Utilizing HTS cables for these interconnections is shown to reduce or eliminate issues of power transfer and right-of-way limitations, electromagnetic fields (EMF), losses, and fault current, due to their ability to carry very high power and manage fault current levels while requiring minimal right-of-way. Alternatively, stand-alone FCLs can achieve a similar objective when coupled with non-fault current limiting cables.

### **KEYWORDS**

HTS, High Temperature Superconductors, Fault Current Limiters, cables, HTS cables, reliability, paralleling substations

[jdiazdeleon@amsc.com](mailto:jdiazdeleon@amsc.com)

## 1 What are High Temperature Superconductors (HTS)?

High temperature superconductors are generally accepted as materials that behave as superconductors at temperatures above 30K. Traditional superconductor materials that only behave as such at temperatures below 30K are usually referred to as low temperature superconductors.

All superconductors exhibit some very unique electrical properties. Key properties and the main benefits when applied to power equipment are:

Property	Benefit	Typical Power Equipment
Zero DC resistance	Low power losses	Cables, generators, motors, transformers
Near step-function increase in impedance above critical current	Current limiting	Fault current limiters, cables
Very high current density	High capacity; compact	Cables, generators, motors
Electromagnetic field expulsion	Low EMF impact	Cables

A few operational requirements exist for HTS materials to behave as superconductors:

1. The operating temperature of the material needs to be maintained below a specified critical temperature ( $T_c$ ),
2. They need to be operated below a critical current threshold ( $I_c$ ), and
3. The overall magnetic field under which the materials operate must be maintained below a critical level ( $H_c$ ).

If any of the above parameters is violated, the HTS material “quenches” and transitions into a very high impedance state. In effect, it becomes a very good insulator. Properly designed and leveraged, this also can be considered a positive property when used in applications such as fault current limiter.

## 2 Stand Alone Fault Current Limiters

As demand for electricity has grown, along with the need for increased system reliability, utilities have added generation and built interconnections to more tightly mesh their networks. Both result in higher fault current levels. As fault levels increase, both fault interruption and the ability of stationary equipment to withstand the forces associated with the higher fault currents become a concern. Utilities have long employed a variety of fault current mitigation techniques such as fault current limiting reactors, selective tripping schemes, and so forth. However, each of these schemes has distinct drawbacks. The ideal would be a reusable, automatic device that did not restrict or impair the operation of the power system during normal operation, but yet could limit fault currents starting with the first cycle peak. This is precisely what HTS-based FCLs do.



Figure 1: 138kV Class HTS-based FCL

A variety of devices have been designed to act as stand-alone FCLs using HTS materials, including resistive FCLs, shielded core FCLs, and saturable core FCLs [1]. As an example, the resistive type FCL has been developed, tested and/or deployed at both medium and high voltage, up to 138kV. See Figure 1.

Resistive FCLs use an HTS-based element to carry the normal load current. One of the greatest advantages of an HTS FCL is that it has essentially zero insertion impedance under normal conditions. This eliminates steady-state losses, voltage drop, and other deleterious effects associated with steady-state impedance. The HTS-based FCL remains in the circuit when a fault occurs. During the fault, the current magnitude will exceed the HTS material’s critical current ( $I_c$ ) and the HTS material will quench.

Resistive FCL’s have been manufactured with both solid rods of bulk first generation HTS material (BSSCO) [2] and coils of second generation (2G) HTS wire based on YBCO material [2,3]. With 2G HTS wires, the HTS material is bonded to a relatively high resistance metallic layer across its length.

When the HTS material quenches, the current shifts to the high resistance metallic layer, essentially inserting a resistance into the fault path and limiting the current flow. See Figure 2. This is also true of fault current limiting 2G HTS-based cables [4]. This effect is immediate and reduces the first cycle peak, as well as reducing the system X/R ratio at that point. In parallel with the HTS element is a shunt, which is typically either a reactor or a resistor. The shunt acts to limit the voltage rise across the HTS element, both protecting it and also carrying the bulk of the current after the first cycle peak. Here the HTS element acts as a very fast (less than half a cycle) current limiting switch. See Figure 3.

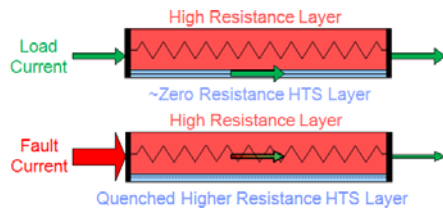

Figure 2: Load and Fault Current flow along 2G HTS wires

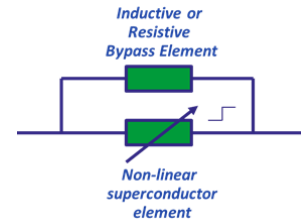

Figure 3: Operation of a Stand-Alone Resistive Fault Current Limiter

HTS-based FCLs are available today for application in the power grid and can serve to reduce fault current magnitudes, eliminate or defer the need to replace circuit breakers, reduce short current forces, and increase system reliability by allowing for tighter grid interconnection as described in the next section.

### 3 Capabilities of HTS Cables

Even though these cables are quite different from conventional power cables, they look, can be spliced, can be placed in ducts or be direct buried just like conventional power cables. However, when HTS wire is used to make an electrical cable, the resulting system has a number of compelling advantages when compared with conventional cables:

1. Much higher power transfer capability.
2. Much lower impedance (zero resistance at DC).
3. Immunity from external magnetic fields, with no emission of any magnetic fields of their own.<sup>1</sup> This essentially removes the need for any EMF related de-rating factors.
4. Elimination of heat within the right-of-way. This essentially removes the need for any thermal de-rating factors.
5. Capability to control fault current magnitudes.

#### 3.1 Power Transfer Capacity

Figure 4 shows a comparison of the power capacity of HTS cables with conventional XLPE (cross-linked polyethylene) cable (based on maximum ampere rated XLPE cables available generally).

The figure makes two very important points:

1. **The same voltage with much more power.** At the same distribution or transmission voltage, many multiples of MVA capability are available over the most commonly available conventional cable. This provides an opportunity to carry significantly more power in existing cable rights of way.

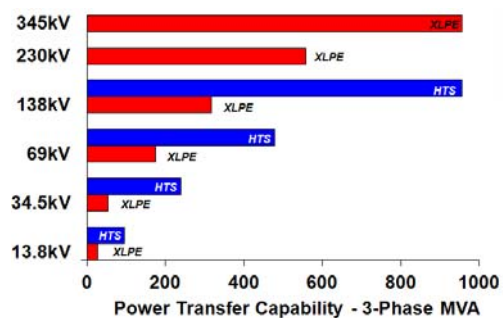

Figure 4: Power Transfer Equivalency of HTS Cables<sup>1</sup>

<sup>1</sup> True for most HTS cable designs.

2. **The same power at much lower voltage.** More power can always be transmitted at a higher voltage. When applied to HTS cable, the higher current density allows for transport of transmission-levels of power at voltages one, two, or more classes lower. This can, in some instances, simplify permitting requirements. One example is a 10kV HTS cable being installed in Germany, replacing an 110kV cable circuit [5].

### 3.2 Simplified Placement and Right-of-Way Considerations

When an HTS cable is manufactured using a layer of HTS conductors to make up the shield layer, the cable becomes inherently self-shielding due to the magnetic field expulsion that occurs with superconductors. The result is that the cables have no emission of any magnetic fields of their own, and makes them immune to existing external electro-magnetic fields. All HTS cables are also refrigerated (usually with continuously circulated liquid nitrogen). A side benefit of this refrigeration is that the cable is now thermally independent from the environment.

The combination of thermal and electromagnetic independence from the environment essentially removes the need for any EMF- or thermal-related de-rating factors normally associated with cable installations and eliminates the need for expensive thermal backfill material. They can be fit into the smallest and most environmentally restrictive environments. They will have no impact on crossing cable circuits or existing metallic infrastructure. These, combined with their high - and de-rating free - current capacity provides very high power transfer capacity with minimal right-of-way.

### 3.3 Fault Current Limiting

HTS cables can also be designed in such a way that they are fault current limiting. As with stand-alone FCLs, this action can subvert the potential for excessive fault current scenarios and eliminate the need for upgrading protection equipment.

## 4 Sample Novel Application of FCLs and HTS Cables – Paralleling Substations to Increase XFMR Utilization Rate

Steady-state equipment loading limits, whether based upon N-1 or N-2 contingency criteria, are set at artificially low levels to ensure that the electrical system is secure and reliable even when experiencing unexpected equipment failure. Conversely, one or two transformers in each substation may be held unused, as spares. Accommodating large load increases from new commercial projects or even new load types such as will accompany PHEV adoption, may require power delivery facilities to be enhanced to increase capacity and effectively serve this new load. While some substations will be able to achieve capacity increases through the installation of additional equipment, many substations do not have the ability to expand, as is often the case in urban areas. One solution is to build new substations. However, in urban environments this is often prohibitively expensive, even if land can be found on which to construct a new substation.

The installation of bus ties between distribution-focused substations serve as an efficient means to utilize more effectively and fully the existing power delivery infrastructure while simultaneously increasing reliability. Several utilities throughout the world have tested HTS systems on their distribution systems. Others are considering them as solutions to solve future problems on the distribution systems. One of the major considerations is using HTS cables to provide new substation-to-substation distribution ties. Many large urban distribution systems have never installed such ties. These systems act more like islanded – or hub-and spoke – grids with no facilities for these substations to back-up one another.

In the following application example, a simple distribution system that has two substations, each serving 100 MW of load is analyzed in detail. Each substation

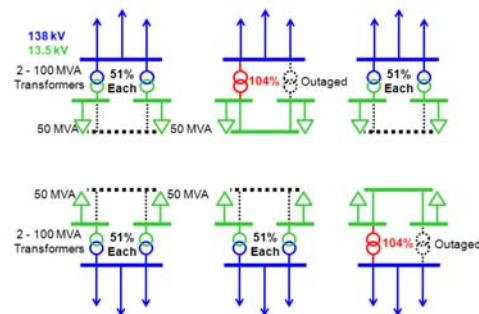

Figure 5: Base Case and Contingency Cases

has two 100 MVA 138/13.5 kV transformers and is now at the point (see Figure 5) where the outage of one of the transformers overloads the remaining parallel in-service transformer.

Since each substation's distribution system is its own island, the available transformer capacity at the adjacent substation is of no value in solving the capacity shortage problem. Typically, utilities will start to look for solutions that increase existing transformer capacity. Figure 6 shows the typical utility solutions that would include replacing the existing transformers with higher capacity ones, adding transformers, or adding a new third substation to the utility landscape.

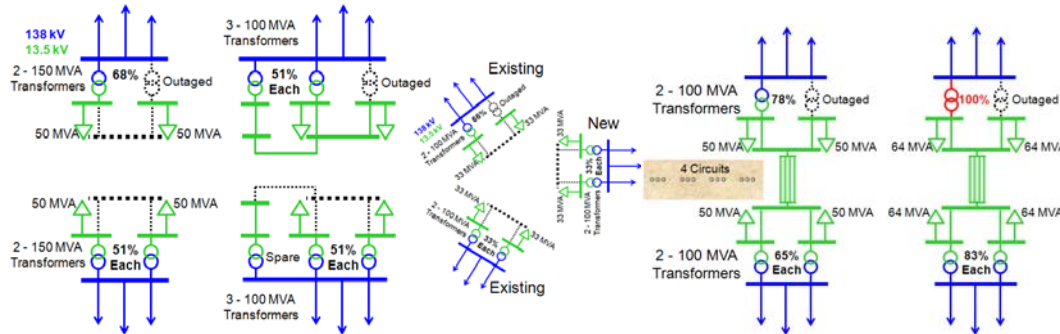

Figure 6: Typical Utility Solutions

While any of these three solutions can solve the overload problems, the issues of available land for substation expansion and/or the increase in fault currents higher than existing fault interrupting/handling capability keep turning up as obstacles to these typical solutions. Today's distribution planners would likely consider substation-to-substation ties. These ties would be made up of three-phase runs of distribution cables with multiple cables per phase for a solution to the example system above. For this distribution transformer outage problem, it would take four cables per phase to get to the desired cable rating of approximately 60 MVA, but the reactance of the cables prevents an even distribution of the post-contingency transformer loadings.

As shown in Figure 6, with all of the installed cables, the utility only gets a capacity increase of approximately 28% before the transformers potentially again experience contingency overloads. It is quite possible that the substation-to-substation ties would cause the substation equipment to exceed its fault interrupting/handling capability including much of the feeder distribution system fault interrupting equipment also.

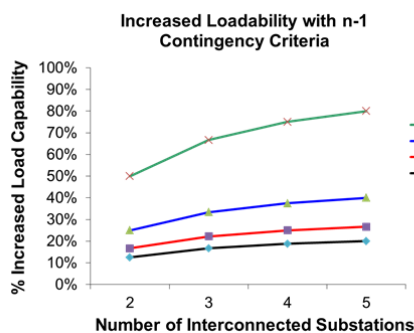

Figure 7. Increased Load Capability for Interconnected Substations Designed for Single Contingencies [4]

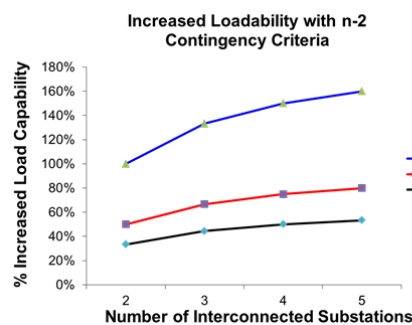

Figure 8. Increased Load Capability for Interconnected Substations Designed for Two Contingencies [4]

The graphs of Figure 7 and Figure 8 display the theoretical increased loading capability of step-down transformers given N-1 or N-2 contingency criteria, respectively [4]. For the example of Figure 5, the networking of 6 low-side buses with 2 step-down transformers per substation, an increased load-ability of 83% is achieved for N-1 criteria. Equation (1) describes the calculation for the maximum increase in load-ability for step-down transformers given equivalent transformers at each substation and a loop or ring connection scheme for the buses.

$$\% \text{ Increase in XFMR loading} = \frac{1 - \frac{C}{ST}}{1 - \frac{C}{T}} - 1 \quad (1)$$

where:

- C = contingency reliability criteria
- S = number of interconnected substations
- T = number of XFMRs at each substation,
- T > C, as it is not practical to lose as many or more XFMRs than exist

## 5 Bus-Tie Issues and Considerations

Planners considering the interconnection of two or more disparate substation buses must consider a number of issues which requires close study. Most important though are two issues surrounding the interconnection itself that are traditionally difficult, if not impossible, to address:

- The current carrying capabilities of traditional underground cables are insufficient to allow the use of only one cable circuit to establish the interconnection. Installing multiple cable circuits is often not practical due to the increased right-of-way requirements, especially as these cables would be competing for space with existing underground infrastructure.
- Even if such a tie is possible, the interconnected substations lead to larger fault currents as each of the paralleled substations can now contribute fault current to a close-in fault. The resulting fault current may exceed the ratings of existing substation equipment.

The higher current ratings of HTS cables in conjunction with their inherent fault current limiting action or as provided by a separate FCL, overcome these critical issues.

ConEd will be deploying a fault current-limiting HTS cable capable of paralleling two substations in its grid in New York, USA, as part of the U.S. Department of Homeland Security's Project Hydra [7]. Conversely, a non-fault current limiting HTS cable could be used and an HTS-based FCL could be placed in series with the cable as is being done on RWE's system in Essen, Germany [2].

## 6 Conclusions

HTS-based cables and stand-alone fault current limiters are now available for deployment on the power grid at both distribution and transmission voltages. The incorporation of HTS material gives this equipment very interesting and unusual application and operational characteristics that can be of great benefit to utility planners and engineers. Incorporating this equipment into the grid requires knowledge of these characteristics and the ability to creatively deploy them in ways that may not be traditional, as these alternate solutions may not have been practical with conventional equipment.

## BIBLIOGRAPHY

- [1] Eckroad, S., "Superconductor Power Equipment, Technology Watch 2010", Electric Power Research Institute, Publication 1019995, Palo Alto, CA, December 2010
- [2] Bock, J., Hobl, A., et al, "Nexans' Superconducting Fault Current Limiters For Medium Voltage Applications – Status And Prospects," 21st International Conference on Electricity Distribution (CIRED), Frankfurt, Germany, June 2011
- [3] W. Schmidt, B. Gamble, et al, "Design and test of current limiting modules using YBCO coated conductors," Supercond. Sci. Tech., vol. 23, p. 014024, 2010.
- [4] Howells, K., Folts, D., McCall, J., Maguire, J., "Fault Current Limiting Power Cables for Mitigation of Fault Levels in Tightly Interconnected Systems," CIGRE Electric Power System of the Future Symposium, Bologna, Italy, August, 2011.
- [5] Stemmler, M., Merschel, F., Oswald, B., Noe, M., "Novel Grid Concepts for Urban Power Supply", 8th International Conference on Insulated Power Cables, June 2011, Versailles, France
- [6] S. Mahmood, "DOE HTS Peer Review: Resilient Electric Grid," Dept. of Homeland Security: Science and Technology Directorate, Aug. 2009.
- [7] Ross, M., Kehrl, B., "Secure Super Grids™: A New Solution for Secure Power in Critical Urban Centers," IEEE T&D Exposition and Conference, Chicago, IL, April 2008.