



21, rue d'Artois, F-75008 PARIS  
http : //www.cigre.org

## CIGRE US National Committee 2016 Grid of the Future Symposium

### **Integrating IEC 61850 and IEEE 1815 (DNP3)**

**A.C. WEST  
SUBNET Solutions Inc.  
Australia**

#### **SUMMARY**

North American has a mature electric power grid. Most grid automation changes are undertaken as evolutionary modifications or extensions of existing systems, rather than by wholesale replacement. This can impact the approach taken when considering the adoption of new technologies or methodologies.

When introducing an IEC 61850 substation automation system into a North American utility, it is often necessary to interconnect it to a SCADA system that is using IEEE 1815 (DNP3). A new standard, IEEE 1815.1, provides guidance on mapping data and functionality between IEC 61850 and DNP3.

Some of the major benefits provided by IEC 61850 lie in its data models and integrated configuration management processes. IEEE 1815.1 shows how to preserve the IEC 61850 model semantics through the DNP3 SCADA system; how to automate the DNP3 configuration and integrate this with the IEC 61850 engineering processes. It also defines how to integrate IEDs that support DNP3 into an IEC 61850 automation system.

This paper outlines the mapping processes defined in IEEE 1815.1 and describes how these can provide a consistent and automated way of integrating IEC 61850 into an existing utility's control system.

#### **KEYWORDS**

IEC 61850, IEEE 1815 (DNP3), SCADA, Substation Automation System, Gateway

## **Introduction**

The integration of the various functions of the intelligent electric power grid brings together technologies that evolved independently. Each function has requirements that have led to the use of techniques and common practices that efficiently and economically address the challenges of supporting that function. This differentiation extends into the architectures and procedures used for management of information associated with the configuration, monitoring, control and fault recovery of each function. As the diverse functions are integrated in order to improve the capabilities and resilience of the grid, it can be necessary to interface, harmonize or adapt information management between subsystems that have differing goals and requirements. Integration is simplified when standardized rules for harmonizing systems are defined and adopted.

This paper discusses the integration of systems that use communication and data modelling that conform to two different but widely-used power grid communication standards: IEC 61850 and IEEE 1815 (DNP3). This is of particular significance in the North American power system where DNP3 is widely adopted and the common upgrade strategy is one of step-wise addition rather than wholesale replacement. In such an environment, an effective strategy for integrating subsystems using these different standards will simplify the adoption of the new IEC 61850 standard into parts of systems that already use DNP3. The IEEE 1815.1 standard serves to define mechanisms and procedures that allow consistent integration of these systems, and may engender tools that allow a high degree of automation of this integration process.

### **IEC 61850**

IEC 61850 was originally developed in order to provide information management for all functions of Substation Automation Systems. The original edition, published in the early years of the new millennium, introduced standardized mechanisms for:

- Data models representing all substation devices and functions
- A common configuration syntax with a single configuration repository for all devices in the substation automation system using XML
- A standard set of services for reporting data, performing control operations and managing diagnostic access to data
- Creation of specific protocols (GOOSE and SMV) to support high-speed coordination of the data processes required to facilitate electric network protection functions and the distribution of time-series analog measurement samples between devices
- Mappings of the data models and services onto existing protocols (primarily MMS) and the newly developed protocols

While the original development of IEC 61850 had its roots in addressing the requirements of substation control and protection systems, ongoing work and new editions of IEC 61850 and associated standards extend the functionality beyond the substation into other power system domains. New data models and functions already cover management of wind farms; hydro-electric power plants and distributed energy resources. Over time, it is expected that additional models and functions will be added to cover all aspects of data management for power system operation.

IEC 61850 is a complex and feature-rich standard that facilitates the creation of powerful automation systems. It has already been deployed in thousands of new substation automation deployments worldwide and is gaining traction in other power system domains.

### **IEEE 1815 (DNP3)**

DNP3 (now IEEE Standard 1815), on the other hand, evolved from traditional SCADA requirements for remotely monitoring and controlling assets in a reliable manner over a wide area using low-bandwidth and potentially unreliable communication systems. It focuses primarily on providing a

light-weight means of transporting relatively simple data values and control commands with a high degree of integrity and resilient methods for recovery from communication system errors and failures. Being more generic and not tied to specific power system data models, DNP3 has seen wide adoption outside of the electric power system, particularly within water and wastewater utilities.

The DNP3 specification was originally published in 1993 and continues to evolve with extensions providing new data types and functions, at the request of the industry through the DNP Users Group, who manages the evolution of the protocol. One guiding principle of this ongoing evolution is to maintain compatibility and interoperability between devices implementing the original specification and devices implementing the most recently added features. Some of the additions to DNP3 include Secure Authentication (a mechanism using strong cryptographic techniques to authenticate communication between devices) and an XML Device Profile syntax for specifying and managing device capabilities and configuration. It is possible to use the DNP3-XML Device Profile to specify the operation of a DNP3 device, including its protocol functionality, the naming of all its data points, etc. The Device Profile also includes a section specifying the mapping between the DNP3 data object map and the corresponding IEC 61850 data model attributes. DNP3 devices can support the capability to read the Device Profile of another device as a means of setting the configuration of the communication with that other device, including information such as data object naming and association with the corresponding IEC 61850 data model attributes. This functionality can enable the automation of the configuration of the mapping between IEC 61850 and DNP3 in a gateway device and the interaction between that gateway and other DNP3 devices.

The Device Profile capability to associate DNP3 data objects with corresponding IEC 61850 data attributes permits the IEC 61850 semantics to be used on DNP3 systems even where IEC 61850 itself is not used. This adoption of IEC 61850 semantics can be an early step when planning a future integration of IEC 61850.

### **IEEE 1815.1**

Due for publication in the first quarter of 2017, IEEE Standard 1815.1 [1] defines a standardized mechanism for a gateway (or protocol translator) to map data between the power system data object models of IEC 61850 and the simpler data types of DNP3. It also defines the mechanisms for mapping functionality (data reporting, control commands, protocol housekeeping, etc.) between these systems. Following its publication by the IEEE, the IEC will consider adopting the document as a dual-logo standard, expected to become IEC TS 61850-80-2.

The need for a mechanism to interface between IEC 61850 and DNP3 was identified by NIST and EPRI during a review of smart grid requirements conducted in 2008. At that time DNP3 was a de-facto industry consortium agreement and not a standard per-se. As it was considered necessary that DNP3 become a recognized standard in order to permit cooperation and coordination with the IEC, the DNP3 specification was reformatted and offered for adoption as an IEEE standard, which occurred in 2010. A second edition was published in 2012 with enhanced security features and work on the next edition has commenced.

### **Mapping Use Cases**

IEEE 1815.1 addresses two basic use cases. Use Case A: Interfacing a DNP3 master with an IEC 61850 Server and Use Case B: Interfacing a DNP3 outstation with an IEC 61850 client.

The most common application is expected to be Use Case A, where a new substation automation system based on IEC 61850 is to communicate with an existing utility control center using DNP3 as the wide-area SCADA protocol. This is illustrated in Figure 1, below. The second use case is most likely to appear where an existing substation that uses DNP3 for internal communication is extended with the introduction of new devices supporting IEC 61850 which must communicate with the other substation devices.

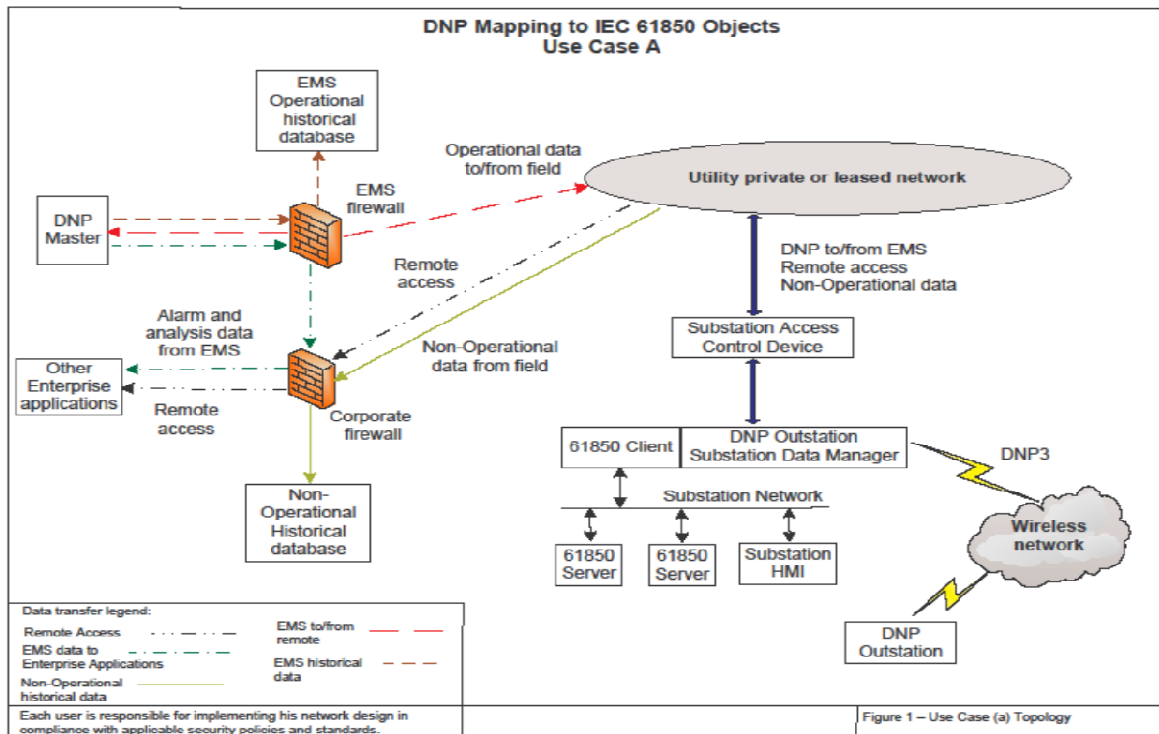

**Figure 1**

There are two subcases of Use Case A for interfacing the new IEC 61850 substation to a DNP3 master: The first subcase (called A1) is for the introduction of a new (greenfield) substation where the allocation of the DNP3 data mapping may be freely chosen. The second subcase (A2) is the replacement of an existing DNP3 outstation with a new system based on IEC 61850, where the mapping of the new data is to match the DNP3 mapping previously used, so as to prevent or minimize the need to reconfigure the master station. A somewhat similar case can occur if the configuration of the IEC 61850 substation is subsequently altered: It may be possible to alter the substation equipment and configuration while maintaining the same data mapping to the SCADA master, thereby minimizing engineering effort and isolating the control center from detail changes in the substation.

### Mapping Details

The IEC 61850 data models include constructs called Logical Nodes that represent power system equipment or power system functions (such as protection or control functions). The Logical Nodes are built from sets of data, where each data element is itself a defined structure of values known as a Common Data Class (CDC). The CDC is a set of data attributes (values) representing an object, such as a Single Point Status (Boolean off/on). The Single Point Status CDC has the Boolean value and other associated attributes, such as quality flags (indicating if the value is valid, etc.), a time of last change, substitution data (if the value can be overridden), naming information, etc.

Each of these attributes may be a simple data type (such as a Boolean, or a floating point number) or could itself be a structure composed of multiple attributes. If these structures are decomposed completely, they are built from a set of simple data types (Booleans, analogs, etc.) which each have a specific interpretation. Each of these “leaf nodes” of the CDC structure can be mapped to a DNP3 data object of a suitable type, in the manner illustrated in Figure 2.

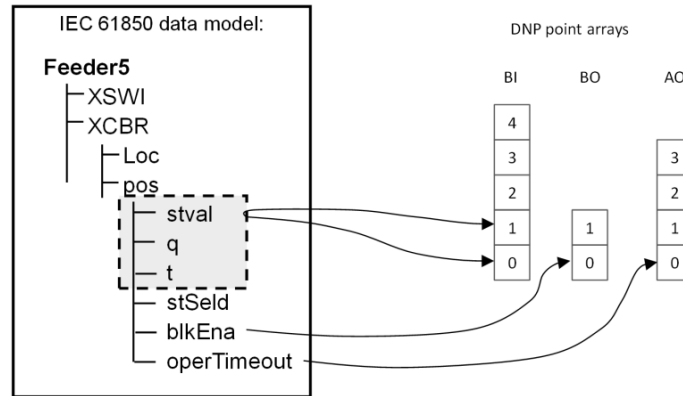

**Figure 2 IEC 61850 Attribute Mapping**

IEEE 1815.1 defines the rules that can be used to perform this mapping. In some cases, alternative mappings may be specified that depend on the capabilities of the device: For example, an IEC 61850 Double Point Status CDC represents the four states of a “2 bit” value that is often used for devices that may be fully closed, fully open, in transit between open and closed or in an undefined (failed) state. The status, quality and event time of this object can be mapped either to one DNP3 double bit binary object or to two DNP3 single bit binary objects, depending on which data types are supported by the gateway and other DNP3 device with which it communicates. Where both types are supported, the double bit binary mapping is identified as the preferred mapping rule choice.

A suite of mapping rules is defined for mapping between the component attributes of all IEC 61850 CDC types and DNP3 data types. By defining these mapping rules for the CDCs from which the Logical Node is constructed, the creation of new Logical Nodes for new domains does not require the creation of new rules, unless some new CDC type must also be created that does not adopt the same characteristics as the existing CDCs.

The mapping of the attributes of the CDC could be performed in several different ways, from a “light” mapping that typically only transfers the value, quality and time (“stVal”, “q” and “t” of the CDC) to a single DNP3 data object {value, quality and timestamp} tuple, or a more complete mapping that also maps additional attributes from the CDC. For many applications, the lightweight mapping corresponds closely to traditional SCADA data reporting and may be sufficient for normal operational purposes.

Another mapping strategy can be to use the data attributes selected for use in IEC 61850 data sets as the basis for choosing the data to be mapped. Data sets are typically configured for reporting a selection of operationally significant data.

The potential exists for a tool to automatically generate a DNP3 configuration that maps all selected IEC 61850 data. This could have templating rules to indicate which attributes of each CDC are to be mapped. An early step for the process is to determine the common set of DNP3 capabilities supported by the gateway and the DNP3 devices with which it communicates. This “merge” of the common capabilities can be performed automatically from the two DNP3 XML Device Profiles, to form a single device profile that specifies the common capabilities. This is then an input document to the configuration tool, from which the tool can identify what mapping options are available. The collection of IEC 61850 SCL files (ICD / CID / SCD) must be processed in the usual manner to produce the SCD file for the system, which is then processed by the mapping tool to add the DNP3 mapping data in the SCD file and configure the mapping information in the DNP-XML file that can then be used to automatically configure the gateway.

The steps and data flow for Use Case A1 are shown in Figure 3, below. This figure shows the input data files for both IEC 61850 and DNP3. Step 2 shows the merging of the DNP capabilities to the common capability set. User input (or suitable template selection options) is needed at step 3 to

identify and select the data that is to be reported to the DNP3 master and possibly to make choices from amongst the available mapping rules. From that point on, the mapping process can be automatic to produce the SCD file with mapping data and DNP3-XML files that define the gateway configuration. The DNP3-XML can then automatically configure the DNP3 master (if it supports configuration by XML import) and the gateway.

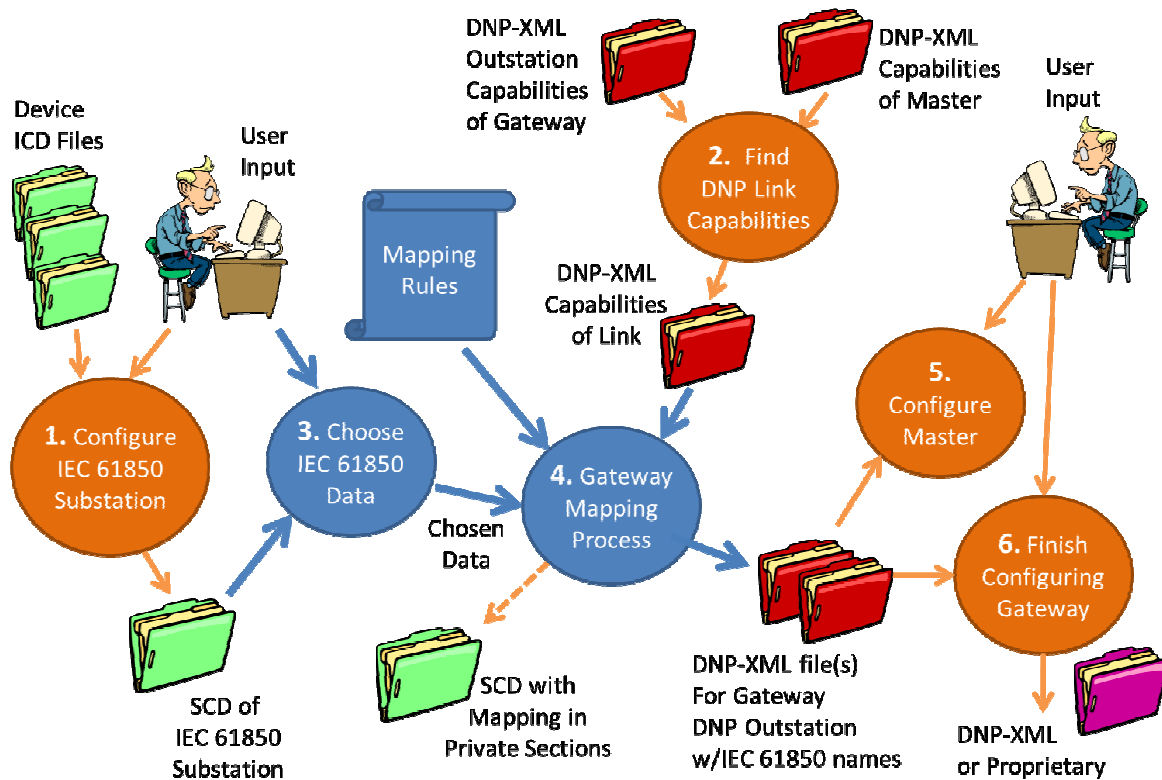

Figure 3 Use Case A1 Mapping Steps

For Use Case A2, more manual intervention is required because the aim is to produce a new DNP3 configuration that appears the same as a pre-defined (ore pre-existing) configuration. For this case, the existing DNP3 configuration dictates the required DNP3 capabilities. The gateway must have been determined to provide these capabilities if the mapping is to be successful, so there is no need to find the common set of capabilities as was done in Use Case A1: The existing configuration from the master’s XML file and the point list it contains specifies the data and format that is required. The user is responsible for identifying what data will be required and explicitly selecting the data to be mapped. The user might also need to make appropriate choices from the mapping rules. Once the data selection is complete (step 3 in Figure 4), the process continues as for Use Case A1.

The mapping requirements for Use Case B are quite different and have more in common with the process for configuring an IEC 61850 server that represents the data collected from the DNP3 IEDs. The procedure is outlined in Figure 5. Here the gateway uses the IED’s XML files to configure its interaction with each IED. Manual intervention will be required to identify what IEC 61850 data models are to be assembled from the DNP3 data in the IEDs and to create the ICD file representing those models. The gateway ICD or IID file can then be used in the remainder of the IEC 61850 configuration process to introduce the data from the DNP3 IEDs as normal IEC 61850 models.

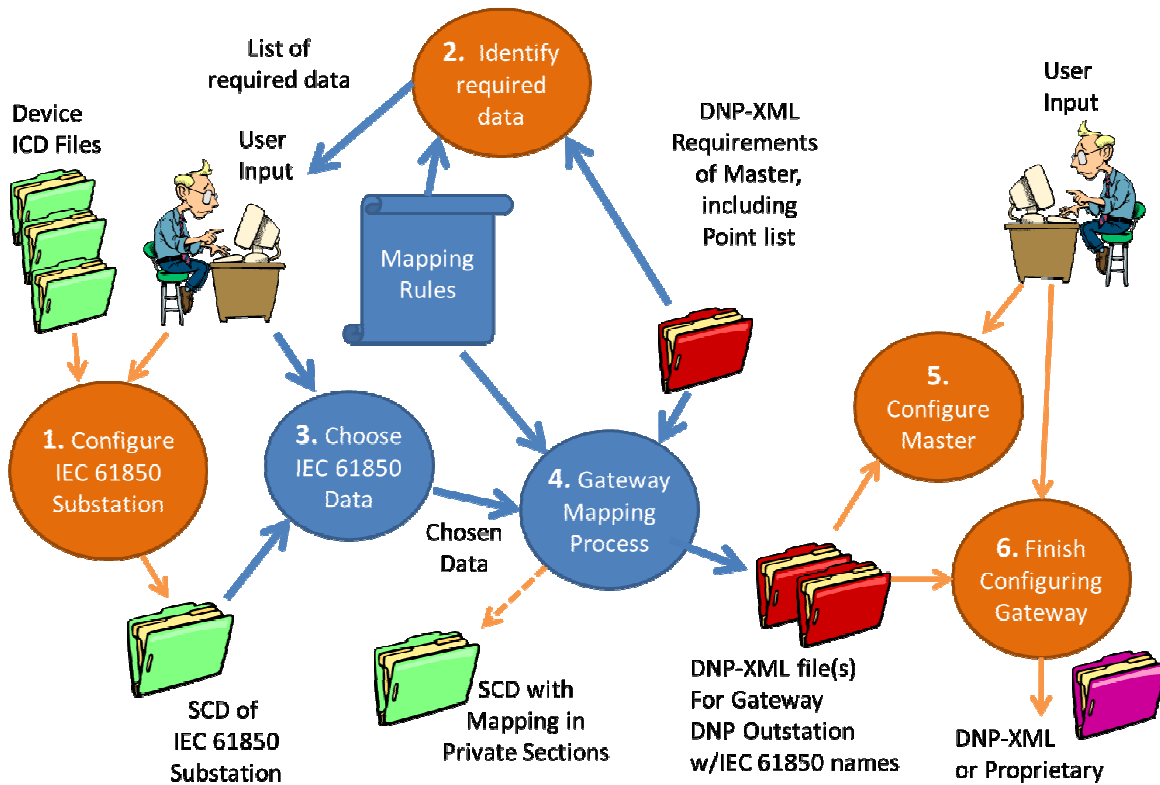

Figure 4 Use Case A2 Mapping Steps

## Function Mapping

IEC 61850 is built on a framework inherited from factory automation principles. The functions and services it uses are closely aligned with those provided by MMS. DNP3 has a somewhat simpler function set, aimed at efficient collection of Report By Exception (event reporting) of changes to monitored data and a two-pass (Select Before Operate or SBO) control strategy that provides exceptional resilience against communication system data errors.

The IEC 61850 functionality that most closely resembles DNP3's RBE process is the Buffered Report system. For many applications it is likely that the only data that needs to be mapped through the gateway will be data that comes from (or is to be placed in) buffered reports.

The control model supported by MMS is fundamentally based on the writing of values to a target device that then causes that device to perform an action. This differs from the SCADA concept of commands being requests with no inherent state and gives rise to quite different steps being performed through a command sequence.

IEEE 1815.1 considers the characteristics of each mapping of control commands between MMS and DNP3 and shows how both command success and command failure cases are to be handled. Each side of the gateway is effectively insulated from the details of the operation of the other side. Examples showing the command flow for a successful SBO with enhanced security command are shown for Use Case A in Figure 6 and Use Case B in Figure 7.

Note that for Use Case A, Figure 6 (from IEEE 1815.1) shows that the status change could be reported by GOOSE, a report or a poll. IEC 61850 GOOSE is not technically guaranteed to report all states of a rapid series of changes on a single value and polling may not observe some changes of state. In normal SCADA (and DNP3) RBE usage, all changes of state are expected to be reported. Hence, in this

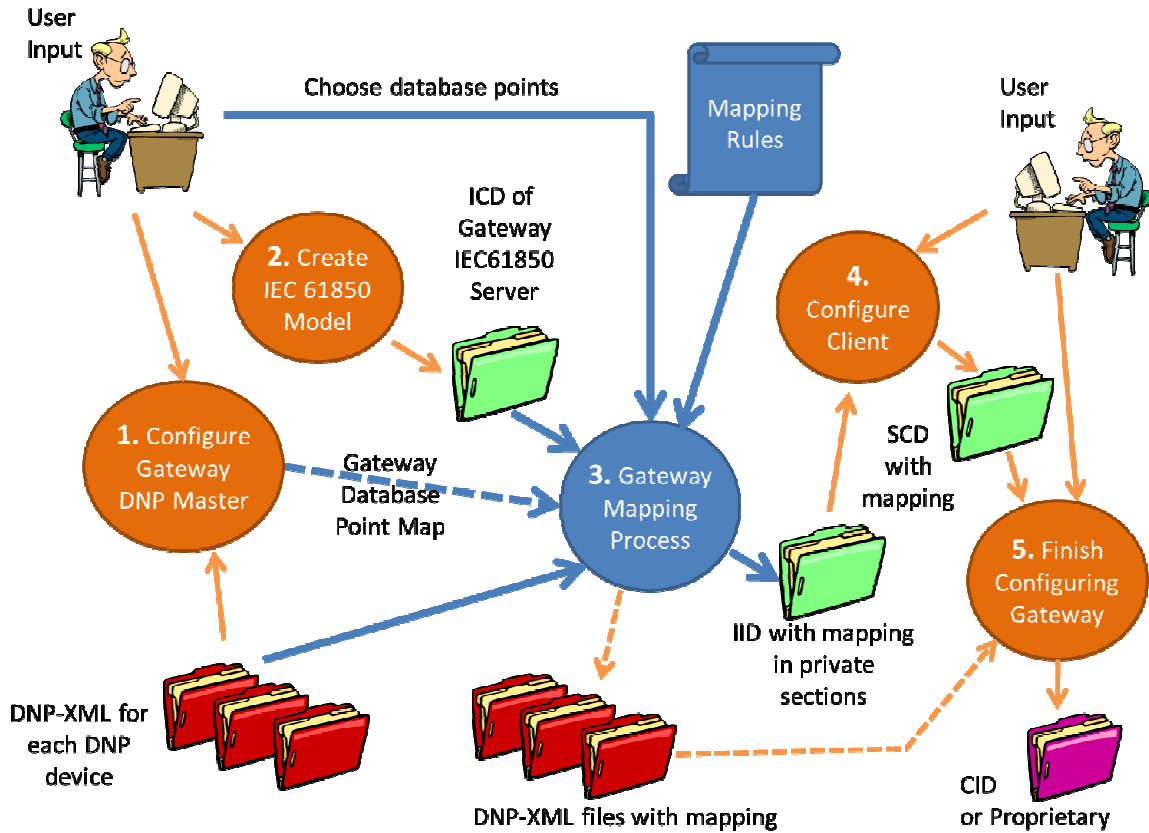

Figure 5 Use Case B Mapping Steps

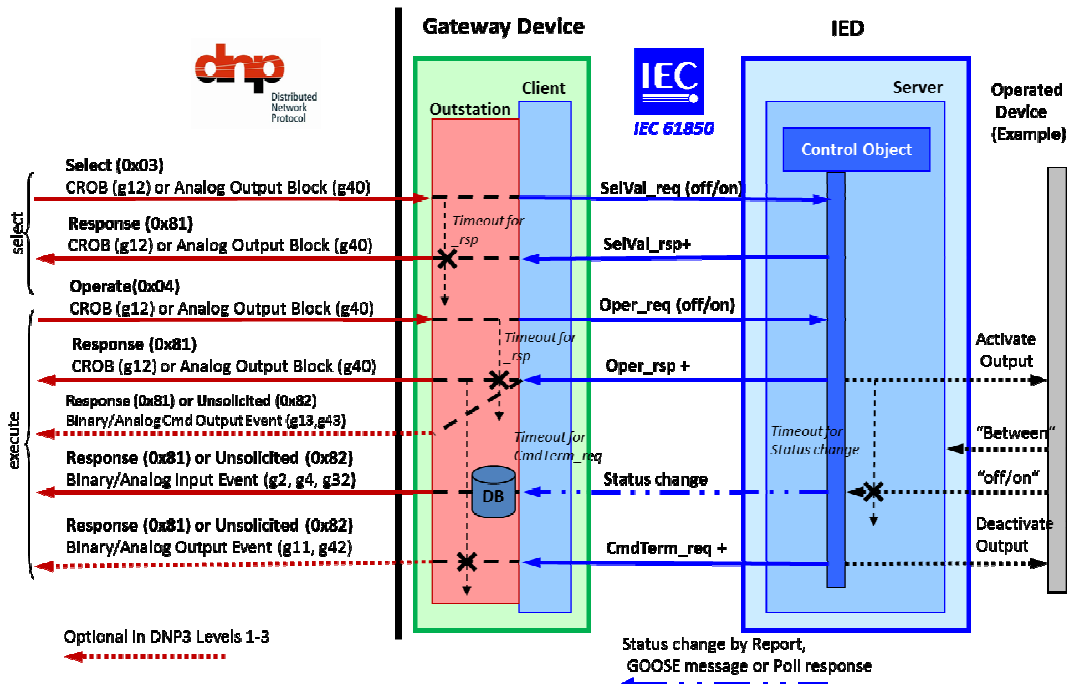

Figure 6 SBO With Enhanced Security (Use Case A)



application, buffered reporting is the preferred method for IEC 61850 to report changes to the gateway. For Use Case B, the choice to use GOOSE, reporting or polling depends more on the purpose for which the value change is used: For process coordination, the use of GOOSE is common.

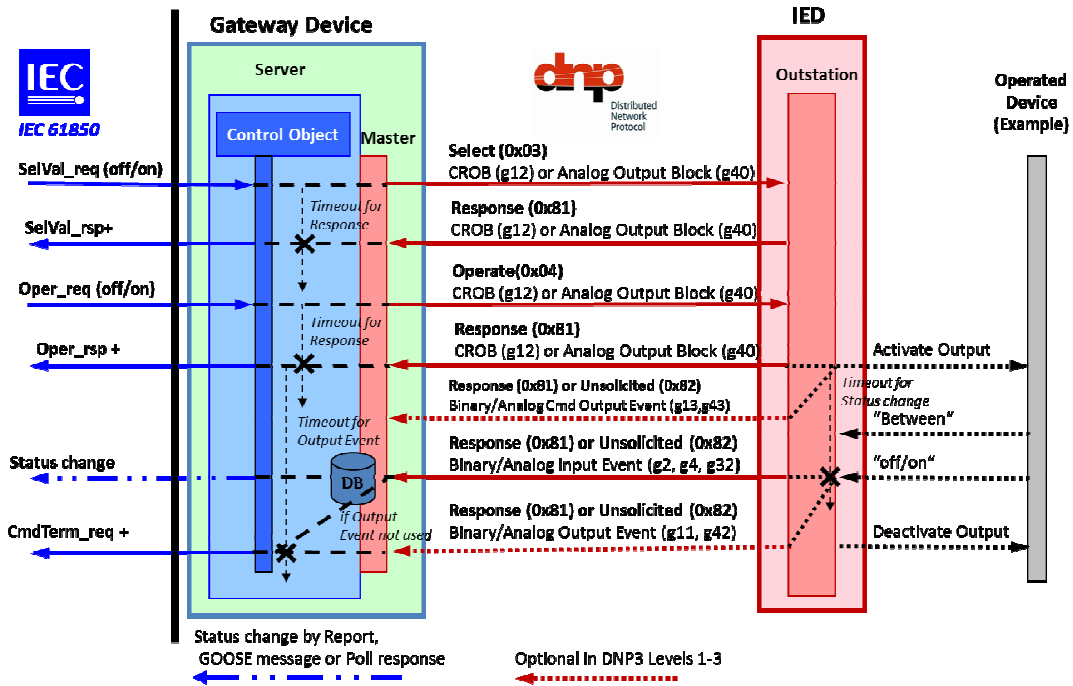

Figure 7 SBO With Enhanced Security (Use Case B)

## Conclusion

IEEE 1815.1 provides guidelines for a consistent method to map between IEC 61850 data models and DNP3. The guidelines can be used to form the basis of a gateway and configuration tool that can, to a large degree, automate the process for implementing a gateway from a greenfield IEC 61850 substation to a DNP3 SCADA control center.

Even where IEC 61850 is not yet in use, the mapping guidelines can be followed to produce native DNP3 configurations that have the same structure and semantics as data sourced from IEC 61850 through a gateway that follows the mapping rules. Adopting these guidelines in the near term may be a prudent step for utilities that plan to deploy IEC 61850 substations in the future.

A side-effect of the mapping process is an automatic association of IEC 61850 semantics with each DNP3 data object. This association is specified in the configuration specified in the DNP3-XML Device Profile which is used to configure the devices. Thus the semantic information is known to the DNP3 outstation and master, even though it is never transmitted over the channel at run time. This gains the efficiency of DNP3 (which might still operate over a low-bandwidth channel) and the rich object model information available from IEC 61850.

Utilities that use or plan to use both IEC 61850 and DNP3 should familiarize themselves with IEEE 1815.1 when it becomes available and adopt its guidelines

**End of text**

**BIBLIOGRAPHY**

- [1] IEEE Standard 1815.1 “Standard for Exchanging Information between networks Implementing IEC 61850 and IEEE Std 1815™ (Distributed Network Protocol - DNP3)”