



21, rue d'Artois, F-75008 PARIS
http : //www.cigre.org

CIGRE US National Committee 2016 Grid of the Future Symposium

Blackstart Hardware-in-the-loop Relay Testing Platform

R. LIU	R. SUN	M. TANIA
Washington State University	Dominion Virginia Power	Dominion Virginia Power
USA	USA	USA

SUMMARY

Blackstart is a procedure to recover power grid from a complete or partial blackout. Once the blackout has occurred, the system operator is responsible for assessing the system condition, restoring the system based on the emergency operation procedures and re-establishing the integrity of the interconnection. In order to achieve a safe and timely blackstart, the system operator should cooperate with regional transmission organization and interconnected utilities.

During blackstart process, the system status is quite different from normal operating conditions. Since the generation capacity is small in each blackstart path, the fault current may also be small comparing with system normal operation. In addition, during blackstart process, there are plenty of blackstart switching operations, such as transmission line energization, load pickup, generator synchronization, and island synchronization. All these blackstart transients and possible small fault current may cause the relay protection function to misoperate.

In order to test the performance of the relay during blackstart process, Real-Time Digital Simulator (RTDS) [1], amplifier, and SEL relay is utilized to build the hardware-in-the-loop relay testing platform. Line distance protection function and time inverse overcurrent protection function are tested for blackstart steady state operation and blackstart switching operation. Testing results demonstrate the possible problems for the relay protection functions during blackstart process.

KEYWORDS

Blackstart, RTDS, Hardware-in-the-loop, Relay Testing, Line Distance Protection, Time Inverse Overcurrent Protection

Ren.liu@wsu.edu

1. INTRODUCTION

Power system is designed to operate in a reliable manner to withstand different contingencies, such as equipment failures. However, at some point, a combination of contingencies or operation error may lead to a partial or complete system blackout, such as the 2003 Northeast blackout [2] and the 2011 Southwest blackout [3]. After a blackout, the system operator is responsible for taking a series of actions to restore the system and re-establish the integrity of the interconnection. The process of restoring the power system to operation is called blackstart.

During blackstart process, the generation capacity in each blackstart path is relatively small comparing with the normal operating conditions, which may lead to a small fault current. In addition, there are lots of switching operations during blackstart process, since the blackout system needs to be restored step-by-step. The possible small fault current and these switching operations during blackstart process may lead to the following problems:

1. The fault current may be less than the relay pickup current.
2. Time inverse overcurrent protection function may respond slower than system normal operation.
3. The relay may misoperate during the blackstart switching transient.

In order to explore possible problems and test the performance of the relay during blackstart process, a relay testing platform needs to be developed. This platform should be able to simulate the flexible power system model and interact with actual hardware in real-time, so that the dynamic performance of the actual relay can be directly tested under different system operation conditions.

In this paper, a blackstart hardware-in-the-loop relay testing platform is developed utilizing RTDS, amplifier, and actual relay. In the Section 2, building blackstart path model in RTDS is introduced. The architecture of hardware-in-the-loop relay testing platform is presented in the Section 3. The testing results of blackstart relay performance is shown in the Section 4.

2. RTDS BLACKSTART PATH MODEL BUILDING

RTDS is a multiprocessor system, which is optimized for the power system real-time simulation. The simulation time-step of RTDS is 50 microsecond, so it is able to simulate the electromagnetic transient dynamic behavior. This feature enables RTDS to simulate all the transient behavior during the blackstart process.

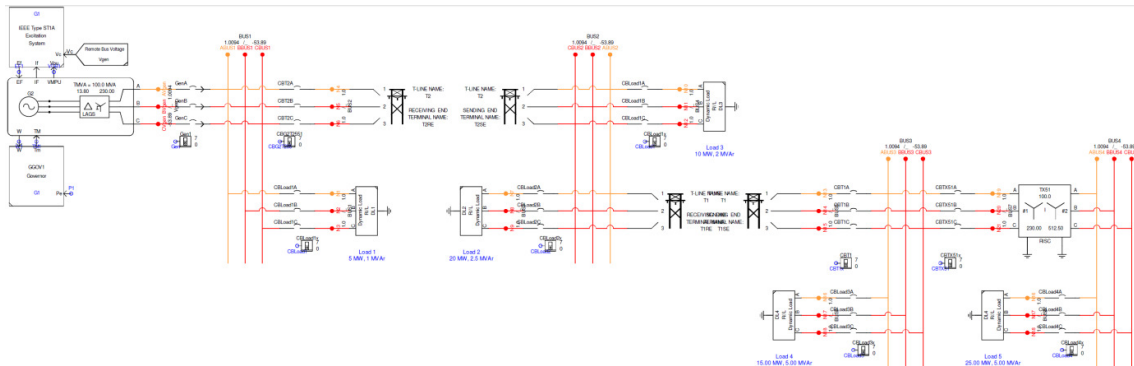

Figure 1. Blackstart path RTDS model

One Dominion Virginia Power (DVP) Blackstart path is simulated in the RTDS. The Blackstart path RTDS dynamic model, shown in Fig. 1, is converted from the MMWG East Interconnection model with the addition of some control components. In this blackstart path, GEN1 is the blackstart unit which is connected on the Bus 1. The transmission line connects Bus 1 and Bus 3. Bus 2 is the tap stations on the transmission line with no transmission breakers. There is a transformer TX1 connecting Bus 3 and Bus 4. There are total five loads in the blackstart path. Multiple circuit breakers are simulated in the model to control the connection of generator, load, transformer, and transmission line. After the RTDS dynamic model is built, the system dynamic behavior is validated during the blackstart procedures.

3. HARDWARE-IN-THE-LOOP RELAY TESTING PLATFORM

RTDS is able to exchange digital and analog signal through numerous dedicated, high-speed I/O interfaces with hardware, such as relays, controllers, in real-time to test the performance of these hardware devices in the simulated power system. This interacting simulation is called hardware-in-the-loop simulation. Fig. 2 shows the architecture of hardware-in-the-loop relay testing platform. RTDS is utilized to simulate the blackstart path in real-time. The Giga-Transceiver Analogue Output (GTAO) Card is used to generate analog voltage and current signals and send them to amplifier. Based on the RTDS analog signal, the amplifier generates high voltage and high current signals to replicate the signals from PT/CT, and sends these signals to actual relay. The actual relay monitors the simulated power system status and creates the control signal when a fault is detected. The digital control signal is sent to RTDS through Gigabit-Transceiver Front Panel Interface (GTFPI) card for tripping the circuit breaker in the simulated power system. Thus, the hardware-in-the-loop relay testing platform is developed and the performance of the relay is able to be tested during the simulated blackstart process.

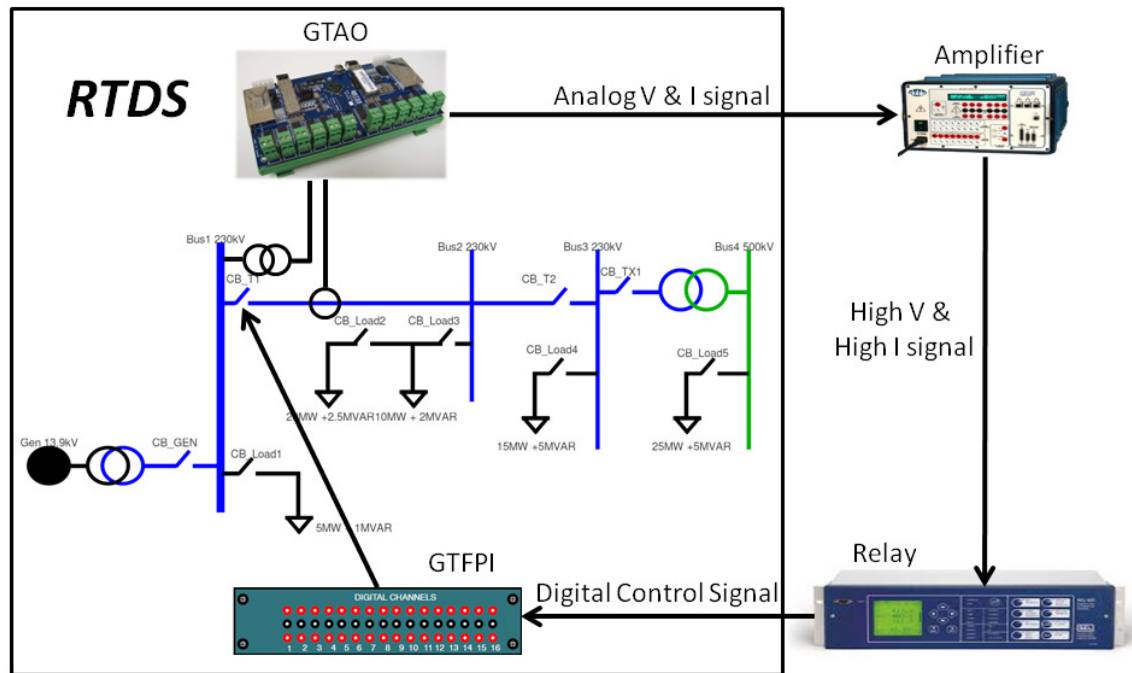

Figure 2. Architecture of Hardware-in-the-loop relay testing platform

4. RELAY TESTING RESULTS

Based on the possible problems discussed in Section 1, four different test scenarios are designed to test the performance of the line distance protection function and time-inverse overcurrent protection during blackstart process.

1. If normal switching operations during blackstart process will cause relay misoperation.
2. If the relay can detect balanced and unbalanced fault occurrence during blackstart process.
3. If the relay can detect pre-existing balanced and unbalanced fault conditions during blackstart switching operation. Operation speed of the time inverse overcurrent protection function is tested under different system conditions during blackstart process.

Fig. 3, two common blackstart switching operations, which are energization transmission line from Bus 1 to Bus 3 and picking up a large load in Bus 2, are simulated in the blackstart path introduced in Section 2. Fig. 3 shows the three phase voltage and current signals, which is monitored by line protection relay (SEL-421) from Bus 1 side. From the Fig. 3, it is clear that both these two switching transients do not trigger the relay operation. The same test has been conducted for all switching operations when energizing the entire path. The relay works properly under no-fault condition.

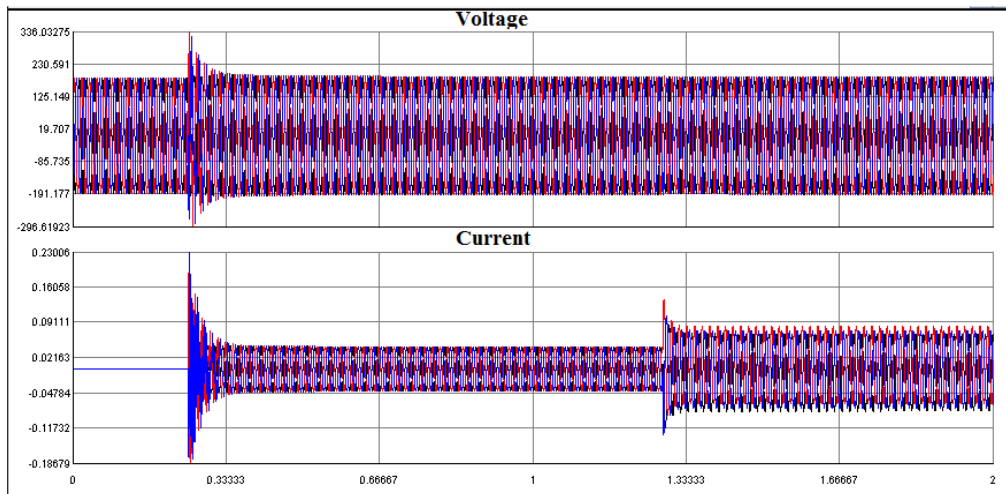

Figure 3. Three phase voltage and current signals from Bus 1 during blackstart switching operations

Fig.4, a Zone-1 single phase to ground fault is simulated on the transmission line from Bus 1 to Bus 3 relay side. It is clear that the relay detects the fault and sends the control signal to trip the simulated circuit breaker within two cycles. The relay detects the fault is a “Zone1, A Phase, Ground” fault and sends the “INST, Trip” signal. All the information matches with the simulated fault. The relay detects the correct fault type and sends the control signal properly.

Fig. 5, in order to test the Zone 2 time-delay backup protection, a phase-to-phase fault is simulated on the same transmission line Bus 3 side, which is in Zone 2 area. It is clear that relay detects the fault and waits for half second. Since the fault is not cleared from the other side of transmission line after time delay, the relay sends the control signal to trip the circuit breaker. The relay detects the fault is a “Zone2, A Phase, C Phase” fault and sends the “Time,

Trip” signal. All the information matches with the simulated fault. The relay detects the correct fault type and sends the control signal properly for Zone 2 fault.

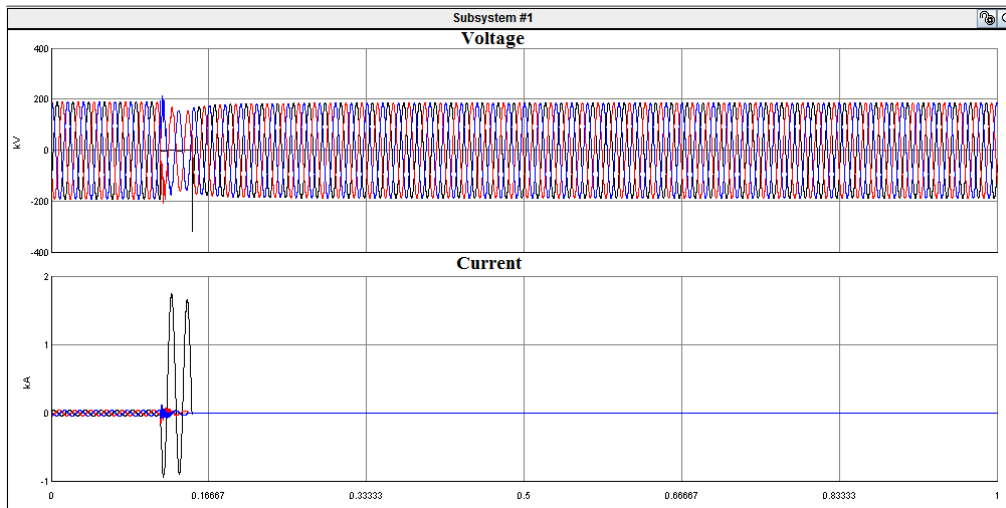

Figure 4. Three phase voltage and current signals from Bus 1 during blackstart steady state operation under A phase to ground fault at Zone 1 area

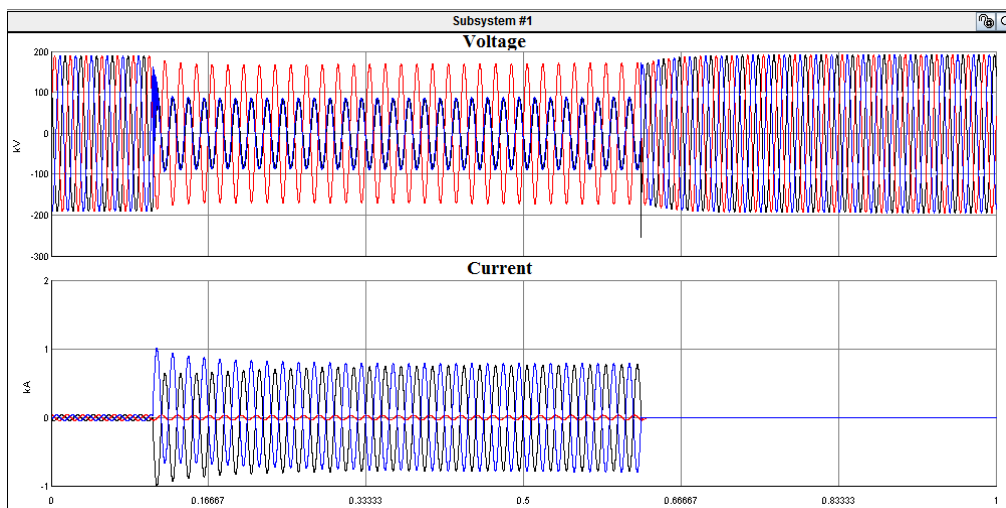

Figure 5. Three phase voltage and current signals from Bus 1 during blackstart steady state operation under A phase to ground fault at Zone 2 area

Fig. 6, a single phase to ground fault is simulated at the same place on Bus 1 side. The fault and the blackstart switching operation, which is energization transmission line from Bus 1 to Bus 3, occur at the same time. In the real world, it refers to the situation when the system operator tries to energize a transmission line with a pre-existing fault due to the blackout. The relay detects the fault and trips the simulated circuit breaker in three cycles, but the relay operation is delayed by the blackstart switching transient comparing with the blackstart steady state operation.

In order to test the Zone 2 time-delay backup protection during blackstart switching operation, a phase-to-phase fault is simulated on the same transmission line Bus 3 side. The fault and the blackstart switching operation, which is picking up a large load at Bus 2, happen at the same time. In this condition, the relay works properly.

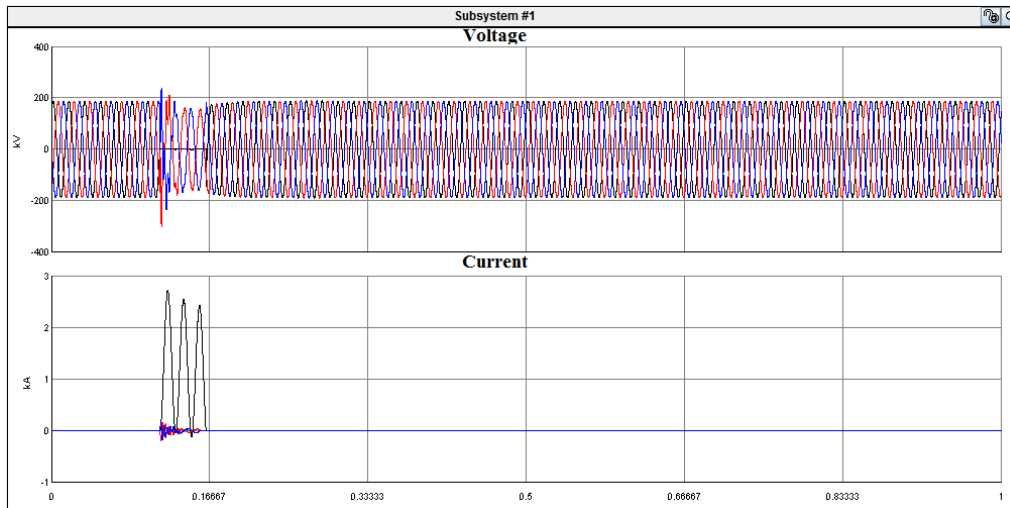

Figure 6. Three phase voltage and current signals from Bus 1 during blackstart switching operation under A phase to ground fault at Zone 1 area

To test the delay on time-inverse protection function, line distance protection function is disabled in the actual relay SEL 421, so that only time inverse overcurrent protection function can trip the circuit breaker. A A phase to ground unbalanced fault is simulated in the Zone 1 area. From Fig. 7 & 8, it is clear that it takes 2.3s and 3.3s to trip the circuit breaker under small system load condition (5MW) and larger system load condition (40MW). However, it only takes couple cycles for time inverse overcurrent protection function to trip the circuit breaker in power system normal operation condition, since fault current in system normal operation is much larger than the fault current in blackstart process. Based on Fig. 9, for the larger system load condition (80MW), the fault current is too small and does not trigger the overcurrent protection function. During the blackstart process, blackstart path may operate as a single generator radial system. If unbalanced fault occurs, the larger system load leads to smaller fault current, which may delay or even fail to trigger the time inverse overcurrent protection function.

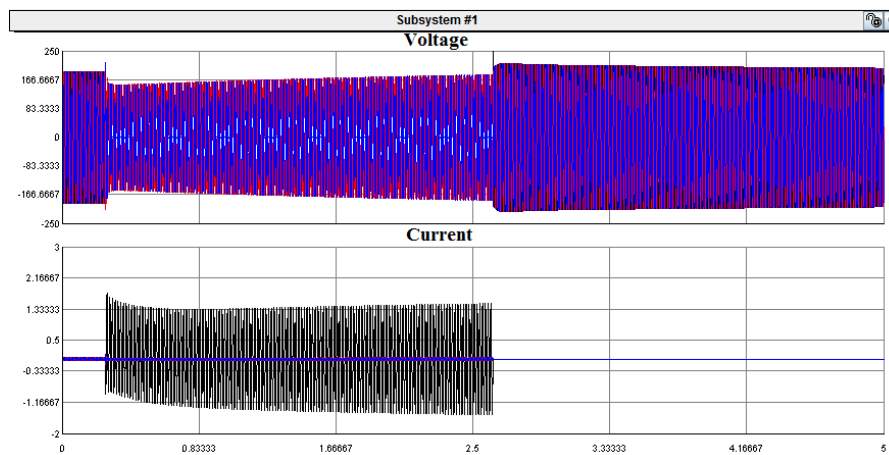

Figure 7. Three phase voltage and current signals for 5 MW system load

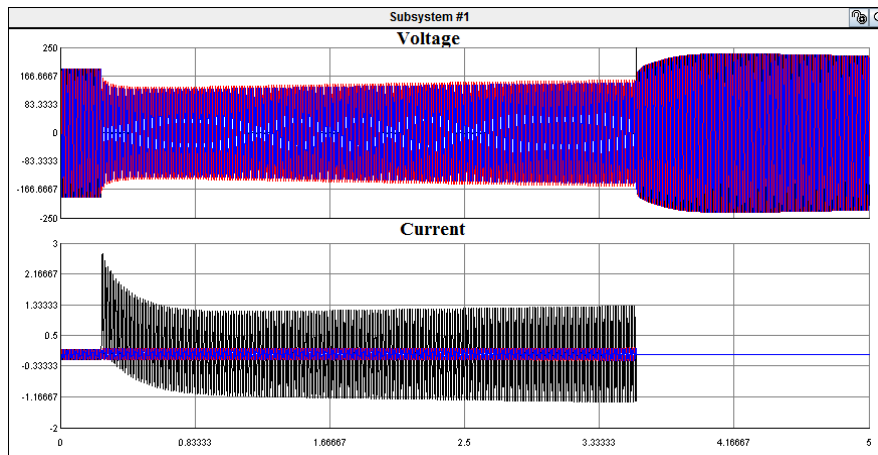

Figure 8. Three phase voltage and current signals for 40 MW system load

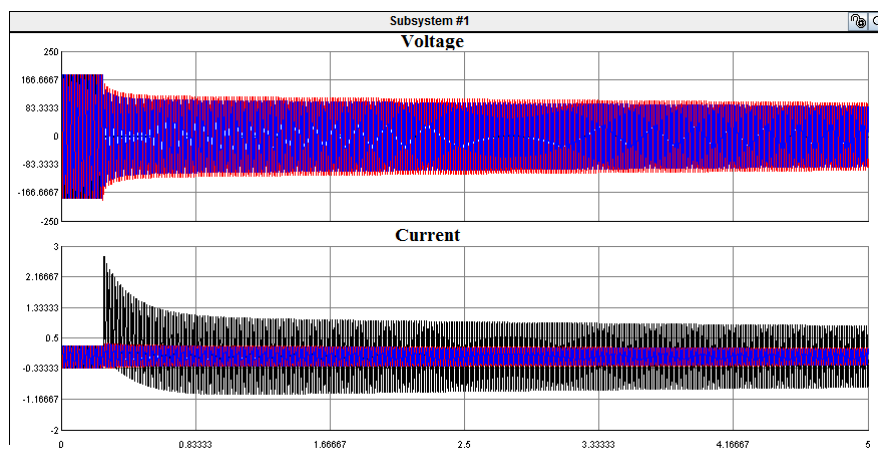

Figure 9. Three phase voltage and current signals for 80 MW system load

CONCLUSION

In this paper, a hardware-in-the-loop relay testing platform is designed to test the performance of the relay during blackstart process. RTDS, amplifier, and actual relay are utilized to develop this platform. The functions of the line protective relays in the blackstart path are tested under different blackstart operation conditions. Possible problems are found for the relay protection functions.

In the future, other types of relays will be tested in more blackstart operation conditions by utilizing this relay testing platform. This platform can also provide the assistance to the system operator when the real blackstart occurs.

BIBLIOGRAPHY

- [1] R. Kuffel, J. Giesbrecht, T. Maguire, R. P. Wierckx and P. McLaren, "RTDS-a fully digital power system simulator operating in real time," WESCANEX 95. Communications, Power, and Computing. Conference Proceedings., IEEE, Winnipeg, Man., 1995, pp. 300-305 vol.2.
- [2] New York Independent System Operator. "Interim Report on the August 14, 2003 Blackout". 2004-01-08. <http://www.hks.harvard.edu/hepg/Papers/NYISO.blackout.report.8.Jan.04.pdf>. Retrieved 2008-09-16
- [3] FERC, NERC. "Arizona—Southern California Outages on September 8, 2011: Causes and Recommendations." (2012).