



21, rue d'Artois, F-75008 PARIS
<http://www.cigre.org>

CIGRE US National Committee
2015 Grid of the Future Symposium

A Case Study on the Use of D-FACTS Devices to Support Construction of New Transmission Facilities

C. THOMAS, J. HAM
Smart Wires Inc.
USA

SUMMARY

Abstract – Use of D-FACTS to control power flow over transmission lines to alleviate overloads when transmission facilities are removed to allow for construction of new transmission facilities is investigated. The economics of D-FACTS are evaluated by comparing with re-dispatching of available generating facilities in the system.

KEYWORDS

FACTS, D-FACTS, Distributed Flexible Alternating Current Transmission Systems, Distributed Series Reactors, Power Flow Control, Line Rating, Line Impedance, Series Reactance

chifong.thomas@smartwiregrid.com

INTRODUCTION

To supply load growth Utility X needs to remove two 60 kV lines on wood poles, which is more than 70 miles and goes over difficult terrain, and rebuild them as two 115 kV lines on steel towers. The construction period is expected to take about 3.5 years. Fig. 1. shows the relevant system in the study area. Power normally flows from Bus 1 to Bus 4, which supplies the Load Center. Generating Plants A and B are comprised of Hydro generators with storage reservoirs and are dispatched first during the 4 months between May and August when water is available; Generating Plants C and D are comprised of Gas Turbine generators and are located in the load center. In addition, generators in Generating Plants C and D have the capability to increase generation from cold-start to full-load in 10 minutes. The cost of operating Generating Plants C and D is \$70/MWh higher than the cost of operating Plants A and B.

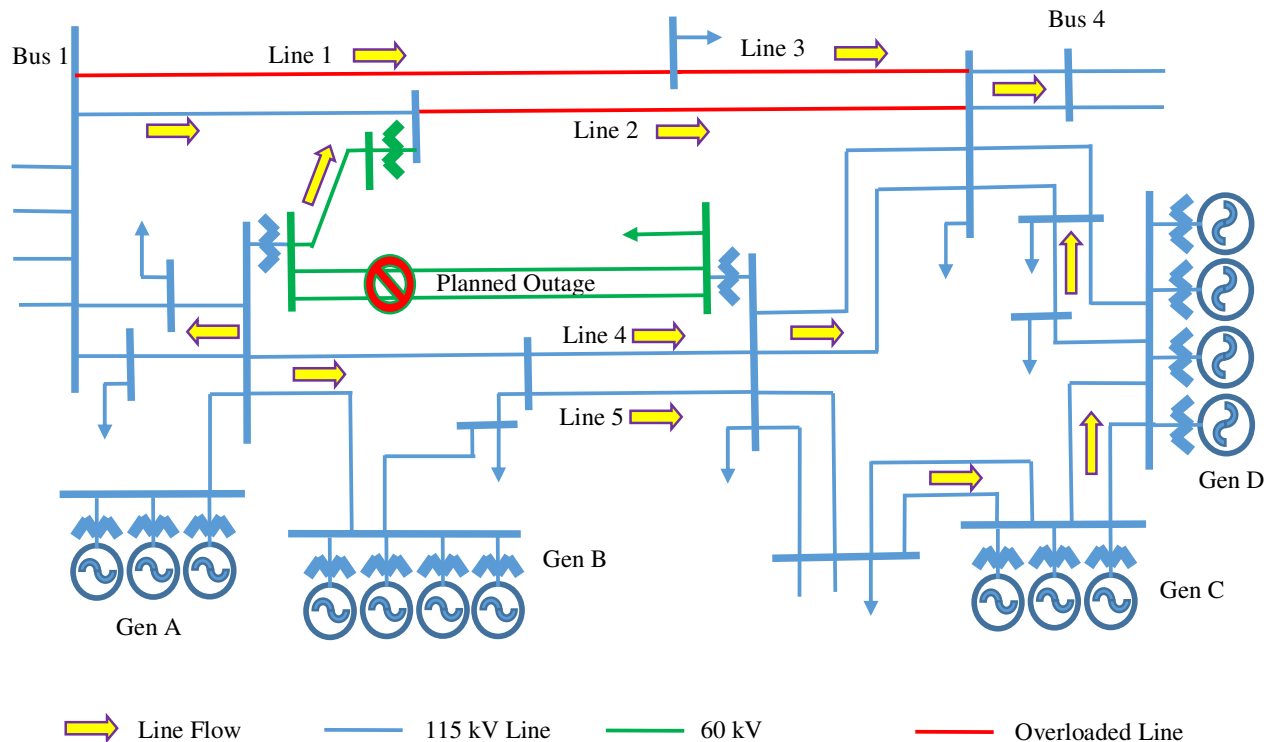

Fig. 1. Utility X System and Study Area

During the construction period, the two 60 kV lines will be taken out of service. Because of this planned outage, overloads can be expected under normal (all facilities in service) conditions unless other actions are taken. Specifically, during all load periods between May and August, overloads are expected on Line 1 and Line 2; overloads are also expected on Line 3 during Off-peak periods. In addition, Lines 1 and 2 have a normal rating of 92 MVA and emergency rating of 111 MVA; Line 3 has a normal rating or 87 MVA and emergency rating of 105 MVA. Line 1 and Line 2 are approximately 60 miles each. Line 3 is approximately 30 miles.

PERFORMANCE REQUIREMENTS

Performance Standards require facility loadings to be below normal ratings, and voltages within normal limits under normal (all facilities in service) conditions. Performance Standards also require facility loadings to be below emergency ratings and voltages to be within emergency voltage limits after the loss of one or more facilities.

METHODOLOGY

Earlier studies have shown that the system would not have any voltage problems, therefore this study focused on resolving potential thermal loading problems. To be implementable in 6 months, only alternatives with short lead times would be viable. The study evaluated two alternatives to eliminate the overloads under three system conditions: Peak, Partial-peak and Off-peak conditions. If the generating plants were dispatched to minimize system production cost, potential overloads would result. The alternatives would control the power flow 1) by dispatching generators out of merit (i.e., running Generating Plants C and D ahead of Generating Plants A and B); or 2) by installing D-FACTS devices on lines 1 and 2.

STUDY RESULTS

Tables I, II, and III show the power flows on the pertinent lines with various generation dispatch patterns and load level under normal conditions. Note that Lines 1 and 2 are expected to overload under all studied conditions, and Line 3 is expected to overload only under Off-peak conditions if no action is taken.

Table I. Generation Dispatch and Line Loadings with and without D-FACTS under Peak (10% of time), Normal Conditions (overloads are listed in red)

Gen Plant	Minimize Production Cost		Alternative 1		Alternative 2		Saving for 4 months
	Gen Dispatch (MW)		Gen Dispatch w/o D-FACTS (MW)		Gen Dispatch w/ D-FACTS (MW)		
A	119		47		119		
B	126		80		126		
Sub-Total	245		127		245		
C	165		246		165		
D	0		40		0		
Sub-Total	165		286		165		\$2,473,240
Line	Line Loading		Loading w/o D-FACTS		Loading w/ D-FACTS		# of D-FACTS Units
	MVA	% of Rating	MVA	% of Rating	MVA	% of Rating	
Line 1	119.1	130	90.7	99	90.9	99	936
Line 2	97.2	107	70.8	78	90.9	100	525
Line 3	51.2	58	23.2	27	23.5	27	
Line 4	85.5	57	59.2	39	102.3	68	
Line 5	85.5	57	59.2	39	102.3	68	
Total number of D-FACTS Units							1461

Table II. Generation Dispatch and Line Loadings with and without D-FACTS under Partial-peak (60% of time), Normal Conditions (overloads listed in red)

Gen Plant	Minimize Production Cost		Alternative 1		Alternative 2		Savings for 4 months
	Gen Dispatch (MW)		Gen Dispatch w/o D-FACTS (MW)		Gen Dispatch w/ D-FACTS (MW)		
A	119		47		119		
B	104		72		110		
Sub-Total	223		119		229		
C	0		110		0		
D	0		0		0		
Sub-Total	0		110		0		\$13,490,400
Line	Line Loading		Loading w/o D-FACTS		Loading w/ D-FACTS		# of D-FACTS Units
	MVA	% of Rating	MVA	% of Rating	MVA	% of Rating	
Line 1	115.8	126	90.9	99	92.1	100	876
Line 2	98.3	108	75.1	82	91.2	100	525
Line 3	57.9	66	33.4	38	34.6	40	
Line 4	85.9	57	62.9	42	102.7	68	
Line 5	85.9	57	62.9	42	102.7	68	
Total number D-FACTS Units							1401

Table III. Generation Dispatch and Line Loadings with and without D-FACTS under Off-peak (30% of time), Normal Conditions (overloads listed in red)

	Minimize Production Cost		Alternative 1		Alternative 2		
Gen Plant	Gen Dispatch (MW)		Gen Dispatch w/o D-FACTS (MW)		Gen Dispatch w/ D-FACTS (MW)		Savings for 4 months
A	119		47		75		
B	138		66		112		
Sub-Total	257		113		187		
C	0		148		74		
D	0		0		0		\$4,537,680
Sub-Total	0		148		74		
Line	Line Loading		Loading w/o D-FACTS		Loading w/ D-FACTS		# of D-FACTS Units
	MVA	% of Rating	MVA	% of Rating	MVA	% of Rating	
Line 1	128.8	141	91.5	99	90.2	98	720
Line 2	117	130	82.8	91	90.2	99	525
Line 3	88.4	101	52	59	50.8	58	
Line 4	103.6	69	69.4	46	99	66	
Line 5	103.6	69	69.4	46	99	66	
Total # of D-FACTS Units							1245

By request of the utility, power flow simulation was not conducted for single contingency conditions because, given that the generators in Generating Plants C and D are very responsive, overloads during contingencies can be mitigated by redispatching generation from Generating Plants A and B to Generating Plants C and D post-contingency. Because the probability of occurrence of single contingency is small, and redispatching is utilized for both alternatives, the cost difference will be small and will not impact their economic comparison.

EVALUATION OF ALTERNATIVES

Assuming that the out of merit dispatch only occurs in 4 months out of the year (May through August) when water is available to supply the Hydro Generating Plants A and B, the savings for one year would be the sum of the savings for each time period in Tables I, II, and III:

$$\$2,473,240 + \$13,490,400 + \$4,537,680 = \$20,501,320 \text{ for 1 year}$$

Therefore, the savings over the 3.5-year construction period would be between \$61.5 million and \$69.7 million depending on the start of the construction period and the number of months the out of merit dispatch would be necessary.

The number of D-FACTS units required would be 1461 added to Lines 1 and 2, at a carrying cost of between \$1.5 million/year and \$4 million/year. The lengths of Lines 1 and 2 are more than long enough to accommodate the required number D-FACTS units. The carrying cost over 3.5 years would therefore be between \$5.25 million and \$14 million.

CONCLUSION

D-FACTS devices can be useful in supporting construction needed to reinforce the system so it can continue to deliver reliable service to customers. Because the D-FACTS devices are redeployable, they can be moved and reused in other areas of need when construction is complete. In addition, the data collected by the D-FACTS devices (such as, current, temperature, sag angle) can also help improve visibility for real time operations.

BIBLIOGRAPHY

- [1] Working Group SC 22-12 CIGRE. "The thermal behaviour of overhead conductors Section 1 and 2 Mathematical model for evaluation of conductor temperature in the steady state and the application thereof" (Electra number 144 October 1992 pages 107-125)
- [2] T. Seppa "Fried Wire?" (Public Utilities Fortnightly, December 2003, pages 39-41)
- [3] Prospectiva del Sector Eléctrico 2002-2011. (Secretaría de Energía. Mexico, 2002).
- [4] Resolución sobre las Modificaciones a la Metodología para la Determinación de los Cargos por Servicio de Transmisión de Energía Eléctrica. (Diario Oficial de la Federación. Jueves 23 de Diciembre de 1999).